

TAKEX

Passive-type Color Sensor / Lighting Check Sensor

CS-R85/CST-R85/BS-R80



Spectroscopic detection of LED light source

Compact RGB Color Sensor



Suitable for lighting from various light sources

Lighting Check Sensor

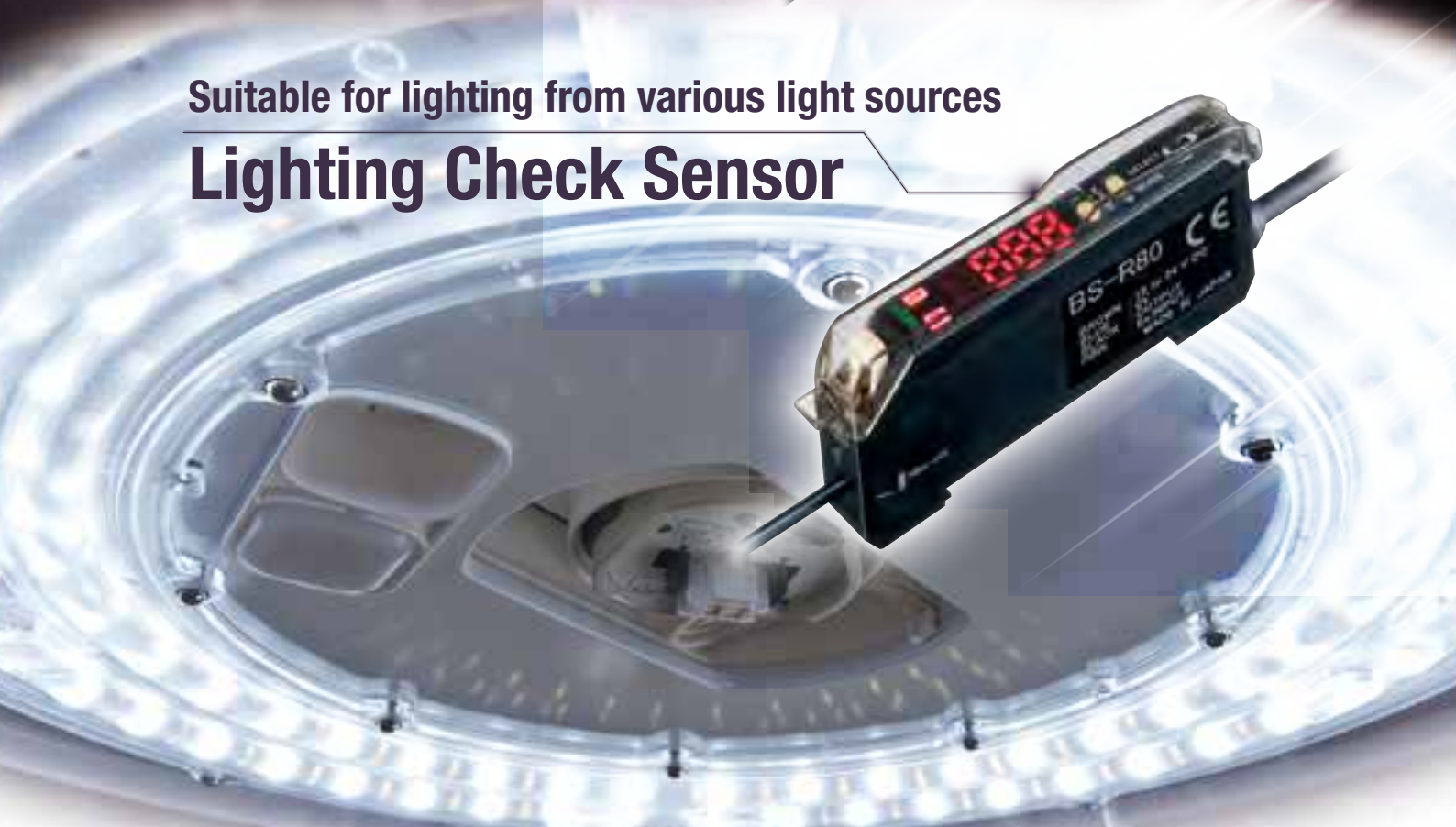

**Spectroscopic sensing realizes
automated sensory inspections**

**Compositely discriminates the lighting status
from DC to pulse lighting via hue and brightness**

Alternative use as an image sensor for simple applications



Automated Visual Inspections

Stably discriminates LED hue,
a visual inspection challenge

Discriminates LED hue differences

Prevention of human-oriented errors

Simple introduction

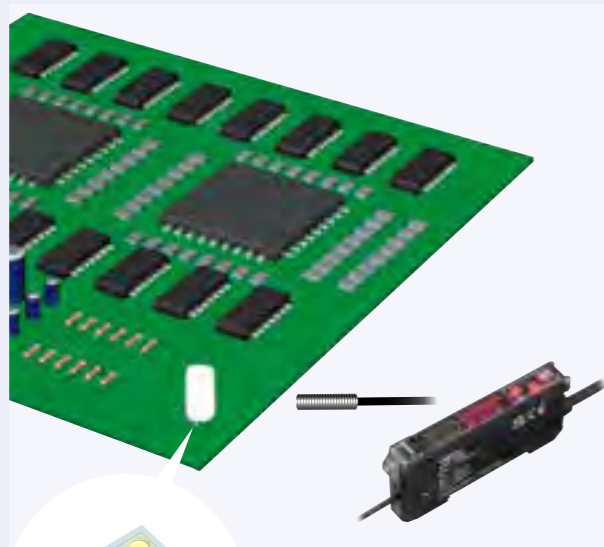

Visualizes Operability through Retrofitting

Easy introduction not only to new,
but also to existing facilities

No large-scale modification is required



Supports Embedded Integration

Fiber-type allows
installation in confined spaces

Space-saving

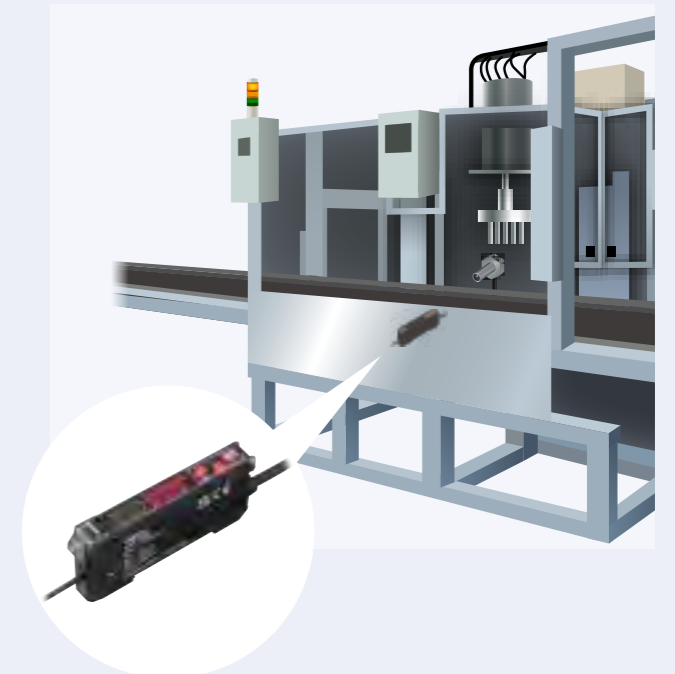

Passive-type Color Sensor

CS-R85/CST-R85

Supports pulse lighting LED light sources

Detects various lighting types from high-frequency pulse to DC LED light sources.

Lighting is automatically identified by the sensor while teaching, requiring no setting by the user.

CS-R85



R/G/B Spectroscopy for Color Ratio Discrimination



Ideal for LED color discrimination

Discriminates LED color ratio difference
Up to 3 colors of reference light can be registered with mode selection

LED wavelength characteristics that CS-R85 can discriminate (Typical example)

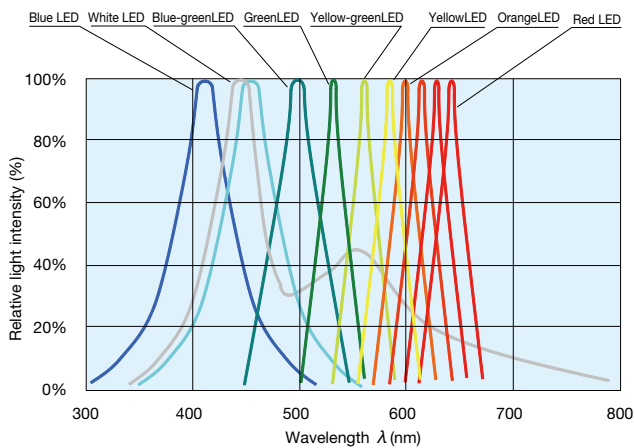

Applications

Color check of lighting LEDs

Discriminates lighting LED colors in the production processes for LED blinkers, tail lamps, and stop lamps.

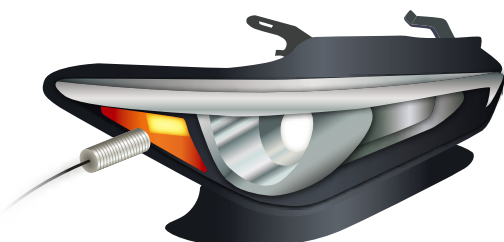

CST-R85



Precisely Discriminates Fine Color Tones or Light Intensities



Discriminates visually-hard-to-identify differences in LED color ratio down to 0.01%

High resolution discrimination of differences in color ratio and brightness of LEDs that have the same color
Integrable into LED inspection equipment

White LEDs that CST-R85 can discriminate (Typical example)

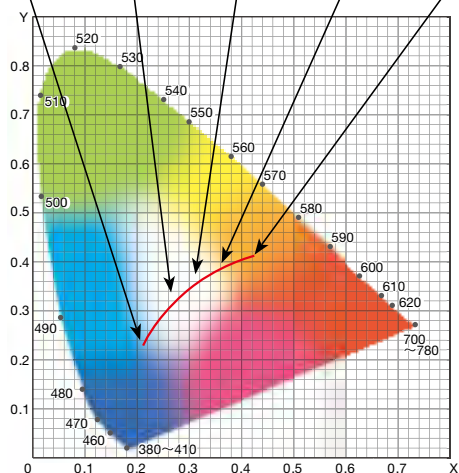
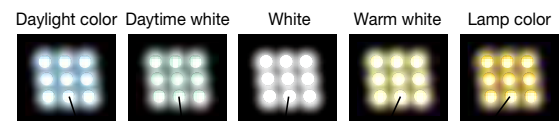

Applications

Mixing different lighting types, lighting check

Example of using both CS-R85 and CST-R85 for lighting check in the mixtures of different product types, as well as for lighting characteristics assessment.



Improved visibility, size, and operability

Extended display from single to dual screens,
increasing visible information
Improved operability with larger setting buttons

Conventional model

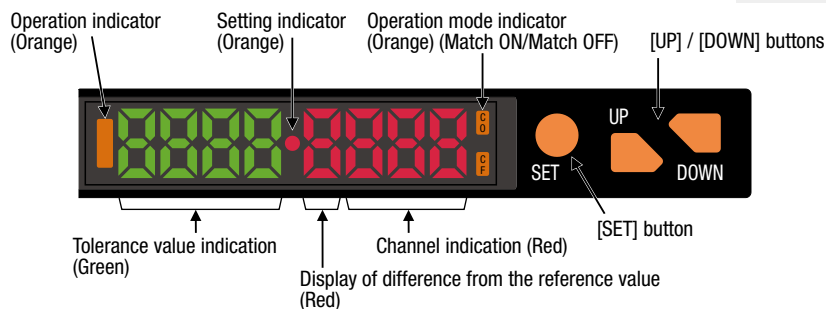

External teaching input

Input devices such as PLCs allow teaching,
without operation from sensors

*For CS-R85, this is available only when set to Mode1

Teaching via remote operation is available



Input device

Timer function

Select from:

On Delay

Off Delay

One Shot

No Timer

Output signal through timer operation is available.
This is useful when a suitable output signal cannot
be obtained in normal operation without timer.

On Delay: disables detection for a short time

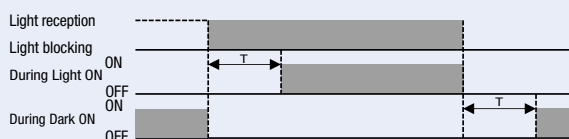

Off Delay: extends the output signal for a specified time

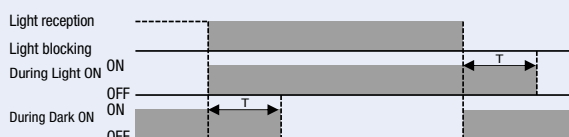

One Shot: triggers signals from the detection timing
for a specified time span

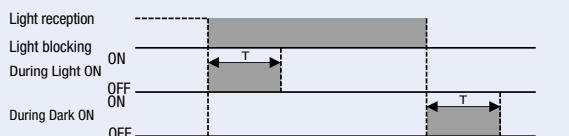

Reduction of maintenance inventory models

Output is changeable between NPN/PNP
Single model can be commonly used even when the
PLC or network of the existing facilities is changed

Supports both NPN input / PNP input

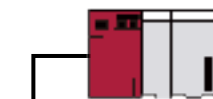

Input device (NPN input)

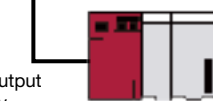

Input device (PNP input)

Use only one output at a time,
as the NPN output and PNP output
cannot be used simultaneously.

Option



CS-ND

Light Reception Adjustment Unit,
CS-ND
Ideal for adjusting the intensity of
receiving light,
such as when the reference light
is too bright

Dedicated fiber unit



FT105BC-CS (Separately available)

SPECIFICATION

Model	CS-R85	CST-R85
Detection method	Identification of color ratios through R/G/B light receptive elements	Identification of color ratios and brightness through R/G/B light receptive elements
Detection distance	Depends on the use environment	
Standard detection target	Light source emitting visible lights	
Power Supply	12 to 24 V DC $\pm 10\%$, Ripple 10% or less	
Current consumption	1000mW or less (40mA or less) at 24V DC	
Reference color registration	Via teaching: 1 color (for Mode 1) Via teaching: 3 colors (for Mode 3)	Via teaching: 1 color
Reference color setting	1-point teaching / 2-point teaching	
External input/output	1 input, 1 output (for Mode 1), 3 outputs (for Mode 3)	1 input, 2 outputs (Output 1: color ratio identification output, Output 2: brightness identification output)
External teaching input	No-voltage input (With or without contact point) (only for Mode 1)	No-voltage input (With or without contact point)
Output mode	NPN/PNP open collector output (operation switch) Load current: 50mA (30V DC) or less, Residual voltage: 2V or less	
Operation mode	Switch "Match ON"/"Match OFF" with the reference color	
Timer	ON Delay / OFF Delay / One Shot / No timer	
	Delay time: 1 to 999 ms (setting available in an interval of 1ms)	
Response time	Auto (10 ms or less at maximum, depending on the illumination conditions of the workpiece) / 50 ms or less / 100 ms or less / 250 ms or less / 500 ms or less (selectable)	
Indicators	Operation indicator, Setting indicator, Match ON (NO) and Match OFF (NC) Indicator: Orange LED	
Display	Tolerance value display: Green LED, 4-digit/ Maximum difference display of color ratios: Red LED, 4-digit	
Protection circuit	Protection against power reversed connection and output short-circuit	
Material	Polycarbonate	
Connection method	Attached cable type ($\phi 4.2$ mm o.d.) 0.2 mm x 5-core, 2m	
Accessories	Instruction manual	

ENVIRONMENTAL SPECIFICATION

Ambient temperature	-25 to +55°C at storage (no freezing)
Ambient humidity	30 to 85 % RH (no condensation)
Protection structure	IP40
Anti-vibration	10 to 55 Hz, double amplitude 1.5 mm, X, Y, Z directions, 2 hour each
Shock	500m/s ² , 3 times each in X, Y and Z directions
Dielectric withstand voltage	1000V AC for 1 minute
Insulation resistance	20M Ω or more with 500V DC Megger

DIMENSIONS (in mm)

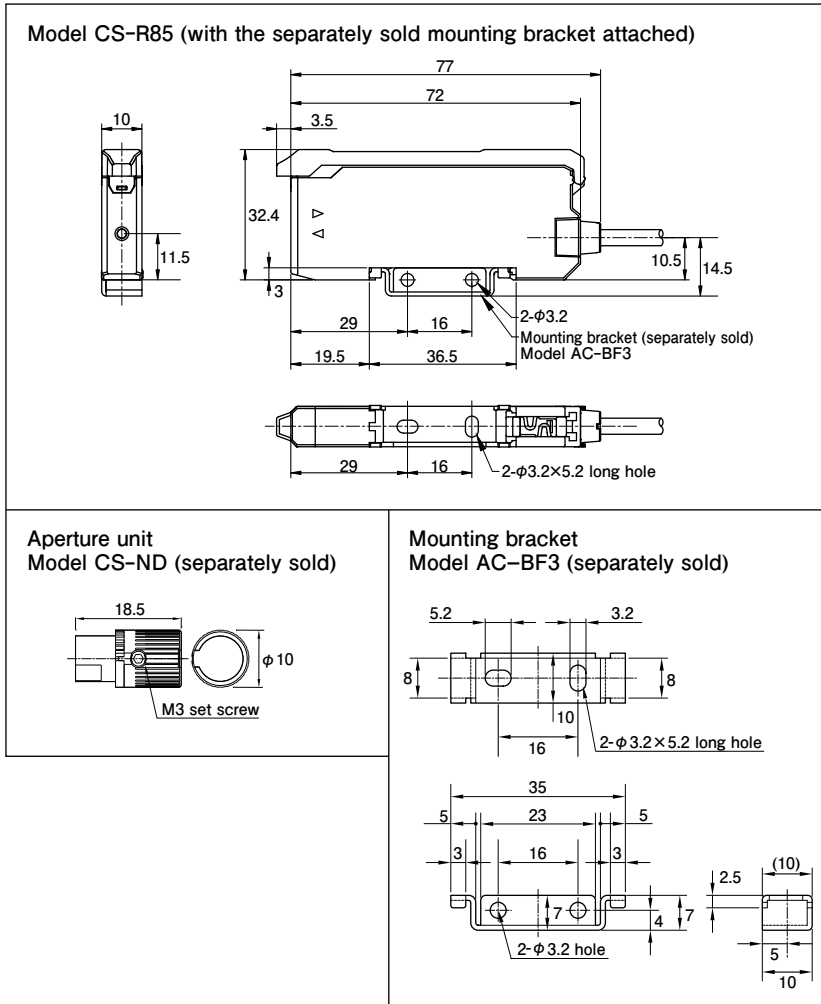

CONNECTION

CS-R85

● NPN Output

· Mode 1 (1 output/1 external input)

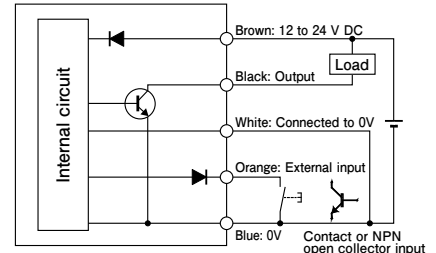

*Connect the white wire to 0V.

· Mode 3 (3 outputs)

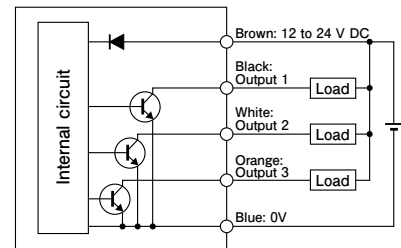

● PNP Output

· Mode 1 (1 output / 1 external input)

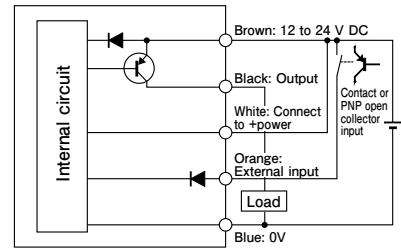

*Connect the white wire to the brown power line (12 to 24V DC).

· Mode 3 (3 outputs)

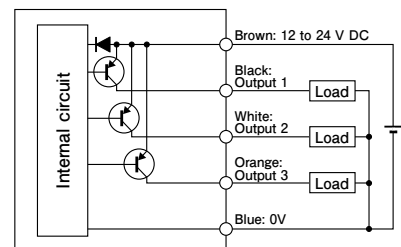

CST-R85

● NPN Output

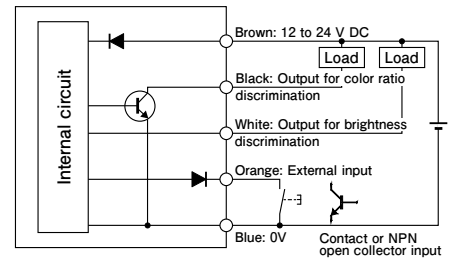

● PNP Output

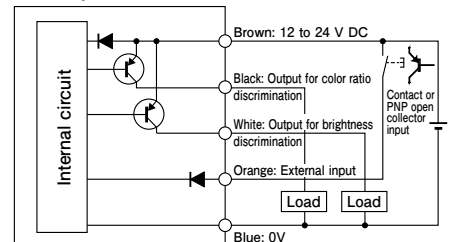

Lighting Check Sensor

BS-R80

Stable Detection of Lighting from Various Light Sources

CE



LED wavelength characteristics that BS-R80 can discriminate (Typical example)

Compatible with various LED light sources such as blue, white, green, orange, red, and infrared, so realizing a wide detection range (standard wavelengths of 400 to 900 nm)

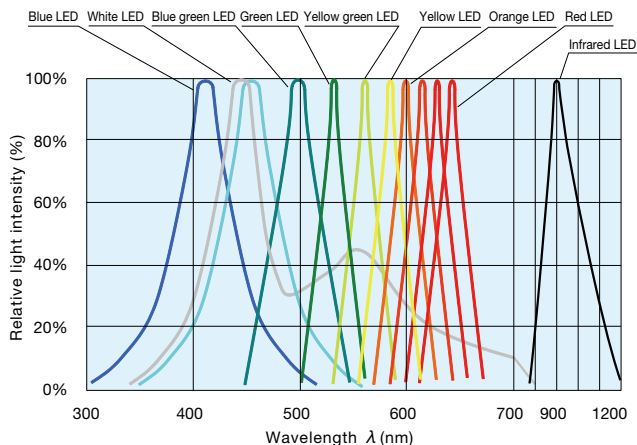

Compatible with pulse lighting LEDs

In addition to DC lighting, pulse LED light sources are covered

Visualizes the lighting status

Digital display enables threshold setting, fine setting, and other settings



Realized high-speed responses

Response time is selectable from 1ms, 10ms, 100ms, and 1000ms

In addition to the final inspection process, introduction into in-line inspection is now possible.

Applications

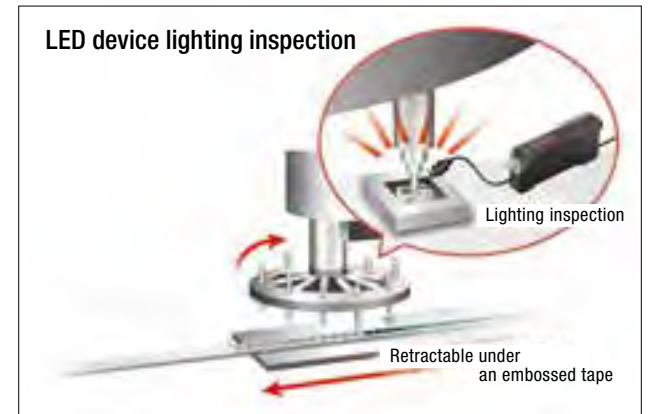

Optimum teaching mode

Optimum setting can be selected from three teaching modes:

Target value setting mode

With the reference light received, automatically set to optimum sensitivity for threshold value setting

Lower limit value setting mode

Performs teaching from reference light, and then the lower limit value for the threshold value setting

Upper/Lower limit values setting mode

Performs teaching from reference light, the lower limit value, and then the upper limit value for the threshold value setting

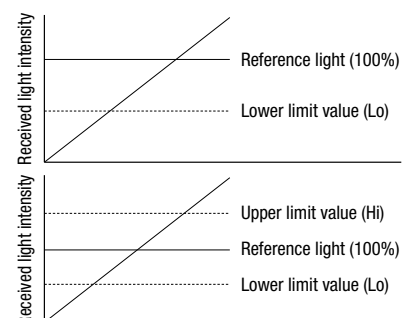

■ SPECIFICATION

Model	BS-R80	
Detection method	Identifying brightness	
Light sensitivity	DC lighting 10 to 10000lx (white LED) / pulse lighting depends on conditions	
Standard detection target	Light source that emits visible light and near-infrared light / DC lighting / pulse lighting	
Power supply	12 to 24 VDC, Ripple 10% or less	
Current consumption	500mW or less (20mA or less at 24V)	
Standard light wavelength	400 to 900nm	
External teaching input	No-voltage input (contact / no-contact) (During target value setting mode teaching only)	
Output	NPN mode	NPN open collector output Rating: Sink current 50mA (30 VDC) or less / Residual voltage 2V or less
	PNP mode	PNP open collector output Rating: Source current 50mA (30 VDC) or less / Residual voltage 2V or less
Operation mode	Light ON / Dark ON (operation mode selectable)	
Timer	ON delay / OFF delay Delay timer : 0ms to 999ms (set in millisecond)	
Response time	0: 1ms / 1: 10ms / 2: 100ms / 3: 1000ms ※1	
Indicator	Operation indicator: *OP*LED (orange) lights when output is issued Basic operation setting mode indicator: *SP*LED (red) lights up during basic operation setting	
Display	Function display (orange) / Numeric display 3-digits (0 to 999, red)	
Operation switch	[+] and [-] push button switches: setting selection / reference light level teaching / parameter change Selector switches: RUN / SELECT / SET selection	
Protection circuit	Power reverse connection / Output short-circuit protection / Output reverse connection	
Material	Polycarbonate	
Wiring	Attached cable (o.d. φ3.7), 0.2mm x 4-cores, 2m	
Weight	Approx. 60g (Cable 2m, including mounting bracket)	
Accessory	Mounting bracket / Instruction manual	

※ 1 Detection is enabled 2 seconds after power is applied.
 ※ 2 Fiber optic cable is optionally available.
 Recommended fiber optic cable: FT-105BC-CS (core diameter φ1.5)

■ ENVIRONMENTAL SPECIFICATION

Ambient temperature	-25 to +55°C (no freezing)
Ambient humidity	35 to 85%RH (no condensation)
Protective structure	IP 40
Vibration	10 to 55Hz / 1.5mm double amplitude / 2 hours each in X, Y and Z directions
Shock	500 m/s ² / 3 times each in X, Y, Z directions
Dielectric withstanding	1000 VAC for 1 minute
Insulation resistance	20MΩ or more with 500 VDC Megger

Dedicated fiber optic cable
FT105BC-CS



■ SPECIFICATION

Model	FT105BC-CS
Length	2m
Ambient temperature	-30 to +70 °C
Materials	Sheath : Polyethylene Core : Plastic
Diameter	Cable : 2.2mm Core : 1.5mm
Bending radius	45R

■ DIMENSIONS (in mm)

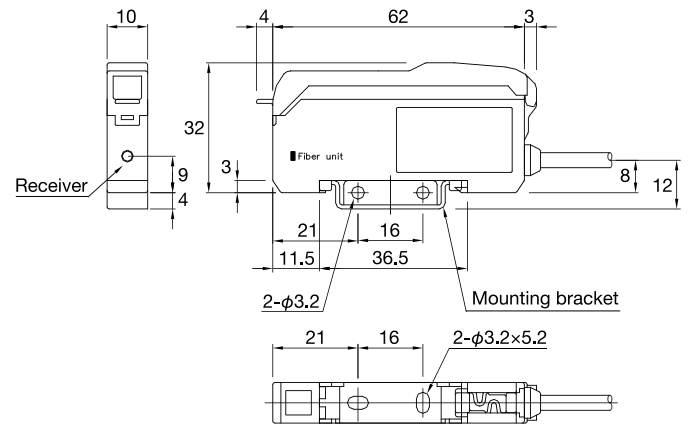

■ CONNECTION

● NPN output mode
Control output (NPN)
External input (teaching)

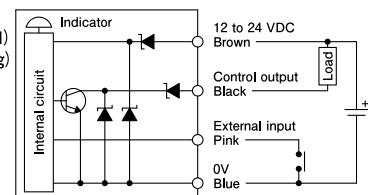

● PNP output mode
Control output (PNP)
External input (teaching)

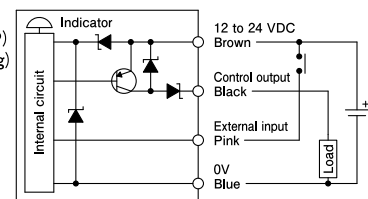

※ When not using the external input, connect the external input cable (pink) to 12 to 24 VDC in NPN mode and to 0V in PNP mode.

■ DIMENSIONS (in mm)

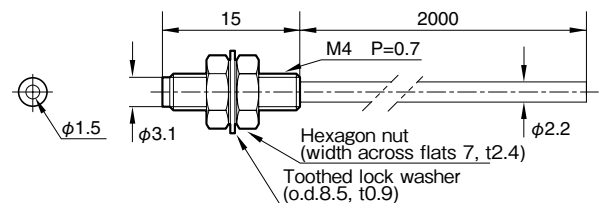

- This product is designed for industrial applications to detect a various kinds of objects. It has no function to prevent disasters, accidents, death or injuries.
- TAKEX will not held responsible for any damage or loss incurred due to accidents, faulty installation, abuse, misuse, improper maintenance or acts of God including lightning surge.
- This product cannot be used as safety equipment.
- This product is designed and manufactured for industrial use. It cannot be used where there is a requirement for a high degree of reliability or considerable care or attention to safety.
- Read this instruction manual carefully and use the product properly according to it.
- This instruction manual including the specifications and dimensions may be subject to change without notice.



Takenaka Sensor Group

TAKENAKA ELECTRONIC INDUSTRIAL CO.,LTD.

5-22 Higashino Kitainoue-cho, Yamashina-ku, Kyoto 607-8141 Japan

Tel: +81-75-581-7111 Fax: +81-75-581-7118

URL : <https://www.takex-elec.co.jp> email : info-ex@takex-elec.co.jp

Distributed by