



- Simple operation of just pressing button
Single touch can make adjustment for transparent object with high transmission
Optical system capable of fine detection of transparent objects employed
- Reflector exclusively for transparent container detection
Tarnish-proof reflector especially designed for transparent objects employed
- Equipped with inverter light suppression circuit
Faulty operation under inverter fluorescent lamps prevented
- IP 67 water resistance allowing washing

Type

Detection method	Detecting distance	Model	Operation mode	出力モード
 Reflector type	 0.1-1m	GA-MT1R	Light-ON/ Dark-ON	NPN open collector
		GA-MT1RPN	selectable (by teaching)	PNP open collector

Optional Parts

Type	Model	Description
Mounting bracket	GA-B1	Vertical mounting bracket
	GA-B2	Horizontal mounting bracket
Protective cover	G-MSB1	Rigid protective cover doubling as mounting bracket.
	G-MTB1	
	G-K7B	
Reflector	K-MT4	Accessory (when purchase separately)

Mounting brackets do not come with sensors. Select and purchase appropriate models according to the mounting conditions

Sensitivity adjustment for transparent object detection difficult with conventional volume type made by single-touch operation

Sample Applications

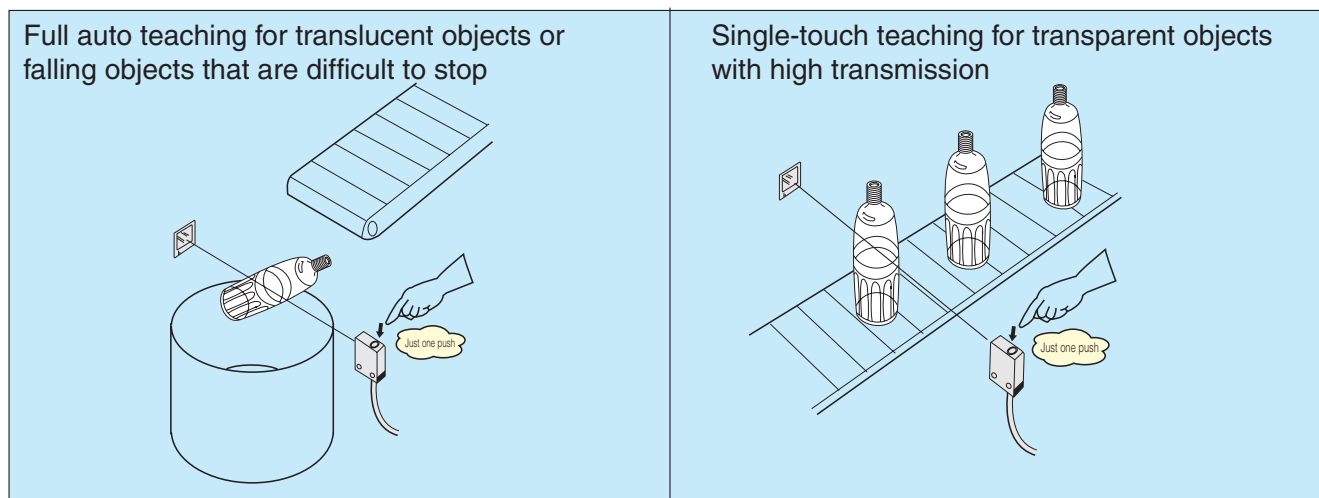

Rating/Performance/Specification

	Type	NPN output type	PNP output type	
	Model	GA-MT1R	GA-MT1RPN	
Rating/performance	Detection method	Reflector type		
	Detecting distance	0.1-1m (with K-MT4 reflector)		
	Power supply	12-24V DC $\pm 10\%$ / Ripple 10% max.		
	Current consumption	25mA max.	25mA max.	
	Output mode	Control output	NPN open collector	PNP open collector
		Rating	Sink current 100 mA (30 VDC) max. Residual voltage: 1 V or less	Source current 100 mA (30 VDC) max. Residual voltage: 1 V or less
		Stability output	NPN open collector	PNP open collector
	Rating	Sink current 50 mA (30 VDC) max. Residual voltage: 1 V or less	Source current 50 mA (30 VDC) max. Residual voltage: 2 V or less	
	Operation mode	Light-ON/Dark-ON selectable		
	Response time	1ms max.		
Specification	Light source	Red LED (700 nm)		
	Indicator	Operation indicator (orange LED)	Stability indicator (green LED)	
	Setting button	For sensitivity setting and Light-ON/Dark-ON selection *1		
	Short circuit protection	Provided		
	Material	Sensor	Lens: acrylic Case: polycarbonate	
		Reflector	Mirror: acrylic / Base: heat-resistant ABS	
	Connection	Permanently attached cord (outer dimension: dia. 4.2) 0.2 sq. 4 core 2 m length		
	Mass	Body: about 60 g / Reflector: about 15 g		
	Notes	Special reflector (K-MT4), operation manual, explanation sticker, (Note) mounting bracket separately available		

*1 Factory settings Sensitivity: Max.
Mode: Dark-ON

Input/Output Circuit and Connection

NPN output
GA-MT1R

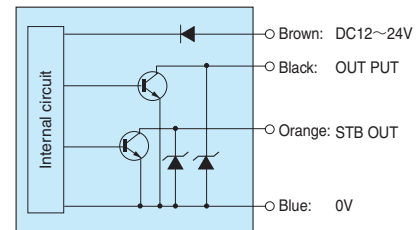

PNP output
GA-MT1RPN

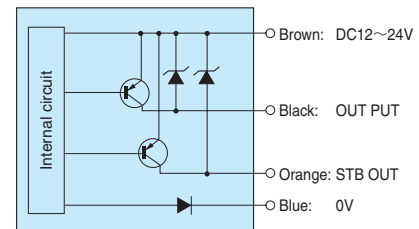

Environmental Specification

Ambient light	5,000 lx max.
Ambient temperature	-25 - +55°C (non-freezing)
Ambient humidity	35~85%RH (non-condensing)
Protective structure	IP 67
Vibration	10-55 Hz / 1.5 mm amplitude / 2 hours each in 3 direction
Shock	500 m/s ² / 3 times each in 3 directions
Dielectric withstanding	1,000 VAC for 1 minute
Insulation resistance	500 VDC, 20 MΩ or higher

Directional characteristics (Typical example)

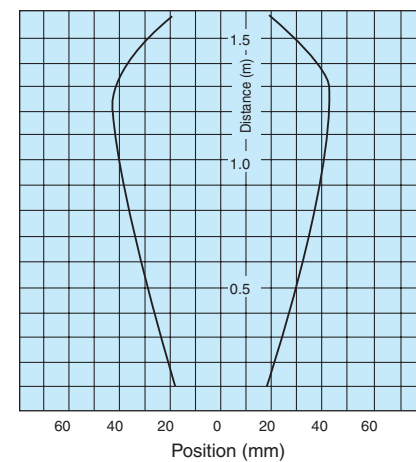

Indicators

The figure below shows the illumination of operation and stability indicators for different received light intensity levels. Set the sensitivity in such a way that the sensor operates in a sensitivity range that allows stable activation.

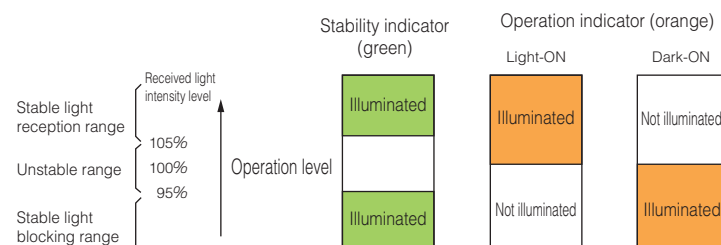

Stability output

When seven consecutive detections have occurred with the intensity of light detected not reaching the stable light reception range, the stability signal is output.

GA-MT1R GA-MT1RPN

For Correct Use

Be sure to follow the instructions in the operation manual provided for correct use of the product.

Part names

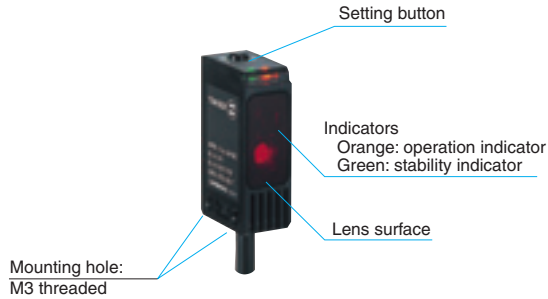

This sensor only has one setting button and no sensitivity adjustment volume or selector switch. Light-ON/Dark-ON switching and sensitivity setting are handled with the setting button alone. Enter the sensitivity setting mode or Light-ON/Dark-ON switching mode by pressing and holding down the button for a period of time as specified below:

Hold down setting button for 2-4 seconds ⇒ Sensitivity setting mode
 Hold down setting button for 5 seconds or longer ⇒ Light-ON/Dark-ON switching mode

Switching between Light-ON/Dark-ON mode

The factory setting is Dark-ON mode. Be sure to check and set either the Light-ON or Dark-ON mode before setting the sensitivity. Enter the Light-ON/Dark-ON switching mode by pressing the setting button for 5 seconds or longer. While the button is operated, the state of the output before starting the operation of the button is maintained.

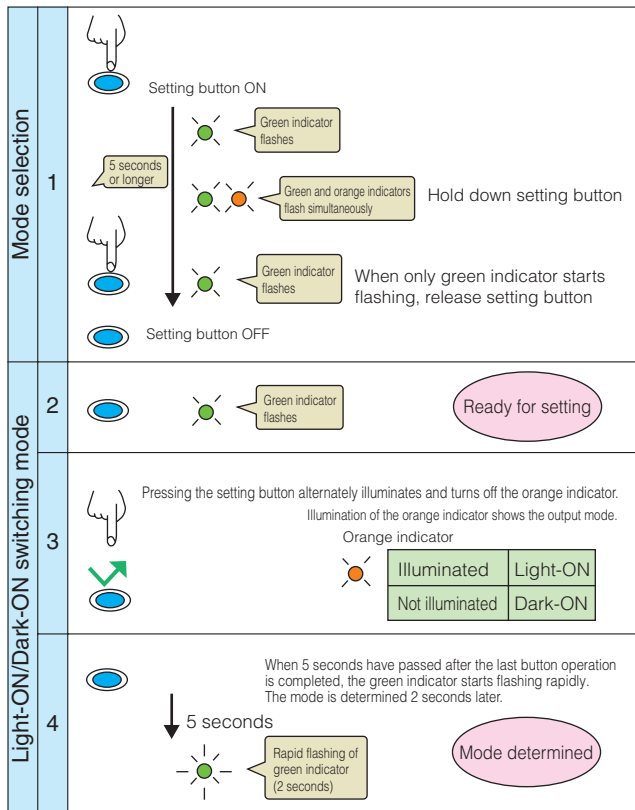

Sensitivity setting

The factory setting is maximum sensitivity. Adjust the sensitivity as required according to the state of the detection object or sensor mounting condition. Use the table below as guidelines:

Detection object	Sensitivity setting
Transparent object with high transmission such as PET bottle	Single-touch teaching-1
Translucent object such as milky white plastic case	Single-touch teaching-2
Continuously moving object such as falling object	Full auto teaching
Object that completely blocks light such as corrugated cardboard box	Maximum sensitivity setting

Single-touch teaching-1 transparent object with high transmission such as PET bottle

With the work removed, select the sensitivity setting mode. Then place the work at a given position and press the setting button once.

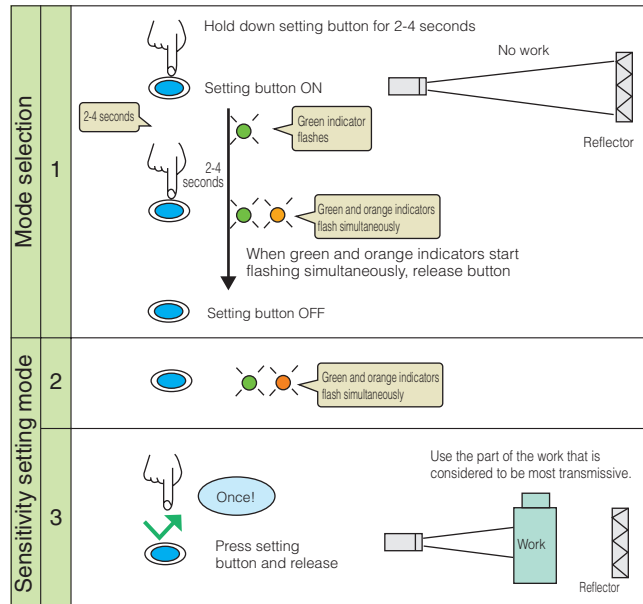

Single-touch teaching-2 translucent object such as milky white plastic case

No work needs to be placed. Set the sensitivity while the light is received. Just a single operation of the button sets the optimum sensitivity for the given received light intensity.

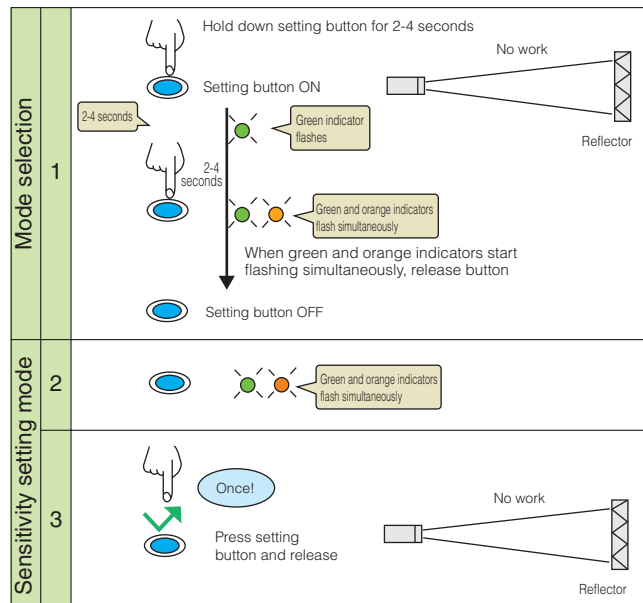

For Correct Use

Be sure to follow the instructions in the operation manual provided for correct use of the product.

Full auto teaching

When it is not possible to make "no-work" state as in detection of continuously moving (e.g. falling) object

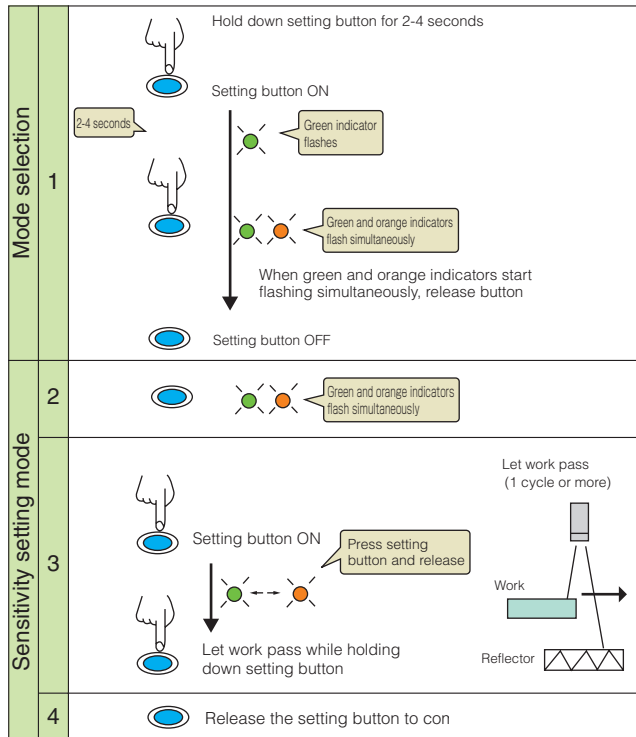

Maximum sensitivity setting

Enter the sensitivity setting mode with the light blocked and press the setting button once. The sensitivity is set at the maximum, which is the factory setting.

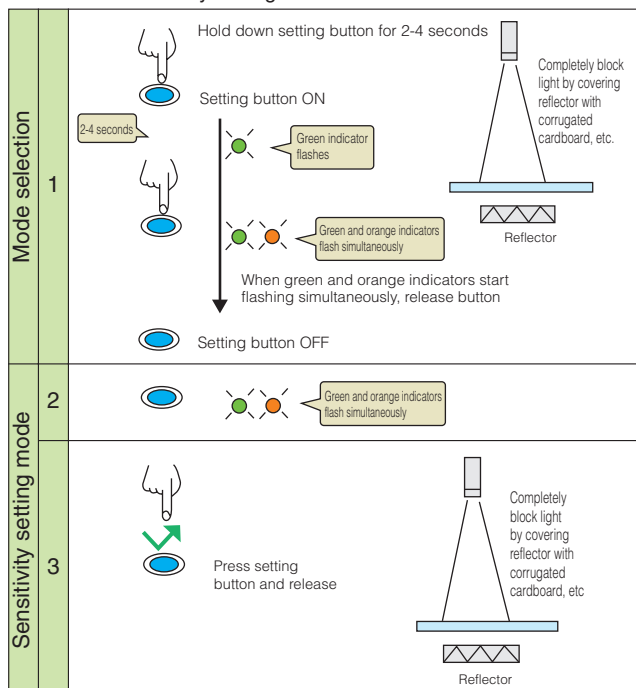

Installation

- Use the special reflector (K-MT4) that comes with the sensor. Using other types of reflector may degrade the performance of the product.
- No mounting bracket is provided. Purchase mounting brackets separately available according to the application.
- Sensor mounting**
For securing the sensor, use screws of an adequate length. If the effective length of the screw to the sensor is too short, the thread of the sensor may be damaged. The mounting holes in the sensor are M3 threaded. Select M3 screws of an appropriate length so that the screw-in length to the body of the sensor will be at least 10 mm. The tightening torque should be up to 0.5 N·m.
- Secure the sensor firmly on a solid base so that the sensor will not move when the setting button is pressed. Inadequate securing allowing the sensor to move when the setting button is pressed hampers accurate sensitivity setting.
- Make sure that the sensor and reflector are fixed before use. If the sensor or reflector is allowed to move, the operation may become unstable. Rotation of the reflector with reference to the sensor is especially likely to cause problems such as chattering.
- If the ambient temperature is low enough for freezing to occur, the operation of the setting button may not feel smooth. In such a case, press hard until the indicator flashes.

Dimensions (in mm)

Sensor body

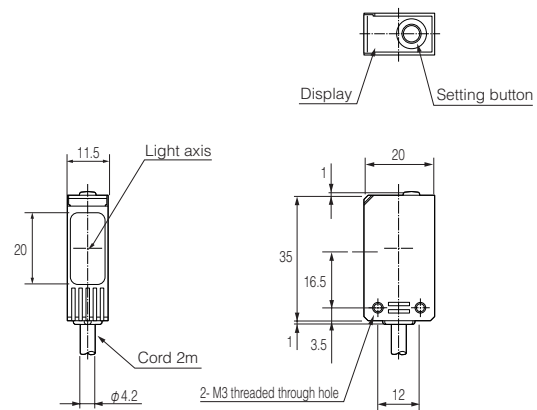

Reflector K-MT4

