



Ultra thin beam and high power are achieved at the same time

LD-M10R (polarization reflector type)

- Ultra thin laser beam is ideal for detecting minute objects
- Long distance detection up to 15 m is possible (with K-7 reflector)
- Various reflectors available for different detecting distances

LD-S20R (diffuse-reflective)

- Variable-focus spot adjustable down to $\phi 1$
(In the range of 80-300 mm from light receiving surface)
- Red laser for simple position checking of emitted light spot
 - Extra thin laser beam ideal for detection of passage/presence or protrusion of minute objects through gap or small hole

Warning



Laser beam employed

Do not look into the beam, do not direct light to human body and follow all instructions for correct and safe use.

Type

Detection method	Detecting distance	Model	Operation mode	Output mode
Polarization reflector type	The detecting distance depends on the reflector used.	LD-M10R	Light-ON/ Dark-ON selectable (with switch)	NPN open collector
		LD-M10RPN		PNP open collector
Diffuse-reflective type	80~300mm	LD-S20R		NPN open collector
		LD-S20RPN		PNP open collector

Optional Parts

Product name	Model	Detecting distance(m)	Effective reflecting surface (mm)	Purpose/application
Reflector	K-15	0.3~7	36×55	For minute object detection
	S-0503A	0.5~7	24×24	For minute object detection
	K-72	1~5	29×8	For minute object detection
	K-MT4	1~7	35×35	For minute object detection
	K-71	3~5	32×19	When there is restriction to mounting of reflector
	K-7	3~15	56×36	For long distance detection

■ Select according to the detecting distance of the application and purpose (separately available).

Note that reflectors other than mentioned above may not be compatible with the sensor.

Rating/Performance/Specification

	Type	NPN output type	PNP output type	NPN output type	PNP output type
	Model	LD-M10R	LD-M10RPN	LD-S20R	LD-S20RPN
Rating/performance	Detection method	Polarization reflector type		Variable-focus reflective type	
	Spot variable range	—————		80mm - 300mm *3	
	Detecting distance	Depending on reflector (separately available)		30-300mm (10 x 10 mm white drawing paper) *3	
	Power supply	12-24V DC ±10% / Ripple 10% max.			
	Current consumption	35mA max. *1	40mA max. *1	35mA max. *1	40mA max. *1
	Output mode	NPN open collector output Sink current 100 mA (30 VDC) max.	PNP open collector output Source current 100 mA (30 VDC) max.	NPN open collector output Sink current 100 mA (30 VDC) max.	PNP open collector output Source current 100 mA (30 VDC) max.
	Operation mode	Light-ON/Dark-ON selectable			
	Anti Interference	Provided			
	Light Emission Stop Function	No-voltage input (contact/non-contact)			
	Response time	0.5ms max.			
	Spot diameter	15 x 7 mm ellipse (at 15 m)		φ 1mm(adjustable range: 80-300 mm from light receiving surface)	
	Smallest detectable mark width	—————		1 mm (black mark on white background) at 300 mm	
	Specification	Light source (wavelength)	Red semiconductor laser (650 nm) Class 2		
Indicator		Operation indicator (red LED)		Stability indicator (green LED)	
Volume		SENS: sensitivity adjustment			
Switch		Light-ON/Dark-ON selector switch provided			
Short circuit protection		Provided			
Connection		Permanently attached cord (outer dimension: dia. 4) 0.2 sq. 4 core 2 m length (black)			
Material		Case: heat-resistant ABS	Lens: Acrylic	Case: heat-resistant ABS	Transmitter lens: glass / Transmitter hood: aluminum / Receiver lens: acrylic
Mass		Approx. 80g			
Accessory		Operation manual, mounting bracket, screwdriver for sensitivity adjustment, warning label, instruction label *2			

*1 Allow sufficient margin in the capacity of the power supply (the laser diode is equipped with a circuit that maintains the same light intensity level by increasing the current if it becomes dark).

*2 The LD-M10 R Series is not provided with a reflector, which is optional.

*3 Distance from the sensor receiving lens surface.

Environmental Specification

Environment	Ambient light	5,000 lx max.
	Ambient temperature	-10 - +55°C (non-freezing)
	Ambient humidity	35 - 85%RH (non-condensing)
	Protective structure	LD-M Series: IP67 LD-S Series: IP66
	Vibration	10 - 55 Hz / 1.5 mm amplitude / 2 hours each in 3 direction
	Shock	LD-M series: 500 m/s ² / 3 times each in 3 directions LD-S series: 300 m/s ² / 3 times each in 3 directions
	Dielectric withstanding	1,000 VAC for 1 minute
	Insulation resistance	500 VDC, 20 MΩ or higher

Input/Output Circuit and Connection

● NPN output

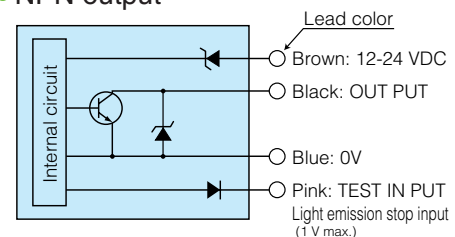

● PNP output

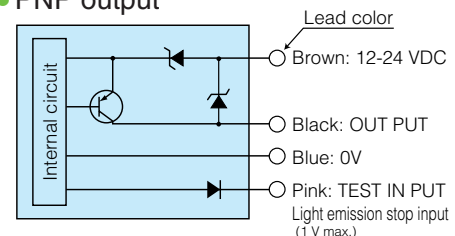

● Slow starter circuit is provided for laser emission.

The laser light is illuminated about 1 second after power-up or reset of short circuit caused by emission stop input.

● The output transistor turns off when load short circuit or overload occurs. Check the load and turn the power back on.

Panel Indication

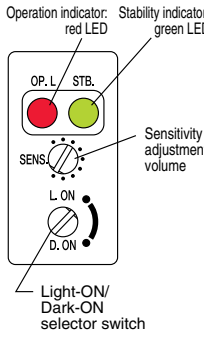

- **Operation indicator (OP.L)**
Red LED illuminated when output transistor is turned on.
- **Stability indicator (STB.)**
Green LED illuminated when received light intensity is less than 80% and more than 120 % of operation level.
- **Sensitivity adjustment volume (SENS.)**
Turning clockwise increases the sensitivity and counterclockwise decreases the sensitivity.
- **Light-ON/Dark-ON selector switch**
Setting the switch to L.ON (Light-ON) activates the output when a certain amount of light is detected. Turning the switch to D.ON (Dark-ON) activates the output when a certain amount of light is not detected.

About indicators

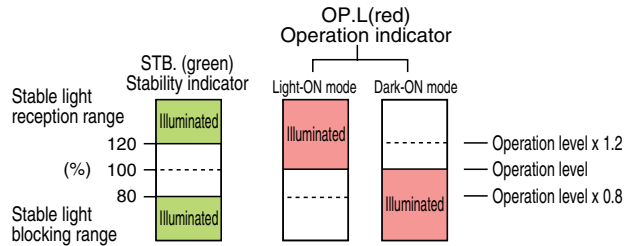

- The operation indicator (red LED) and stability indicator (green LED) indicate the levels as shown above. After light axis alignment and sensitivity adjustment have been completed, repeat activation and deactivation to make sure that the sensitivity is in the stable activation/deactivation range.
- Setting within the stable range increases the reliability against variation of environment after setting.

Using Light Emission Stop Function

- Short-circuiting TEST IN PUT (pink) and 0 V (blue) stops the laser light emission at arbitrary timing. When not using the light emission stop function, connect TEST INPUT (pink) to the positive terminal of the power supply (brown).

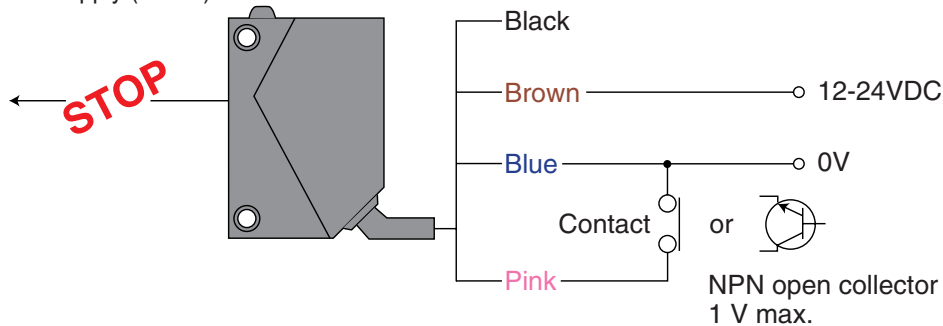

For Correct Use



- Do not use the product for detection for the protection of human body.
- When using the product for safety purposes, ensure safety with the control system as a whole as well as the detection.
- This product is not explosion proof.

- The semiconductor laser used in this product falls under the following class as defined in JIS C 6802 "Safety of Laser Products."
 - Class 2 (Emits visible radiation from which the eyes are generally protected by the aversion reactions)
- This product employs a parallel beam of laser and care should be taken not to allow the laser light to enter human eye directly or by specular reflection. Never look into the laser radiation outlet of the transmitter connected to power supply. Looking straight into the laser light may damage the eye.
- This product is provided with warning and instruction labels as shown below for notifying and alerting the operator of the sensor of the degree of danger. After the product has been installed, attach the labels in prominent locations on the sensor.

Warning label



Instruction level

- Class 2

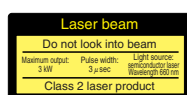

- The radiated laser beam is elliptic due to the characteristics of semiconductor laser. In addition, diffraction pattern is generated due to optical diffraction phenomenon.



- Be notified that this product uses semiconductor laser and is prone to deterioration due to surge current or static electricity.
- The laser diode is equipped with a circuit that maintains the same light intensity level by increasing the current if it becomes dark. For this reason, allow sufficient margin in the capacity of the power supply.
- Always avoid use in which the power is turned on and off consecutively.
- Be sure to turn off the power before moving including mounting and removing or repairing.
- Follow the notes on safety and handling in the operation manual provided for correct use.

Sample Applications

LD-M10R Series

Detection of position of vehicle in multilevel parking garage

Checks for any protrusion of vehicle in multilevel parking garage.

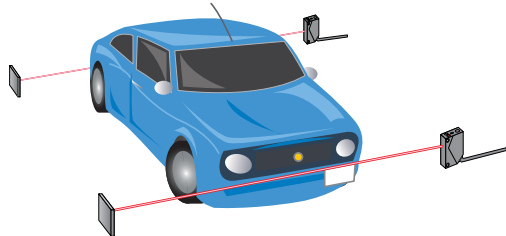

Detection of displaced cassettes

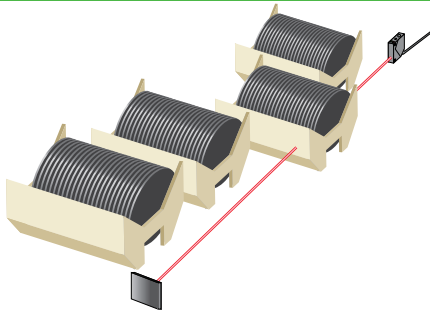

Setting/adjustment

- 1) Arrange the sensor face-to-face and in line with the reflector. Swivel the sensor vertically and horizontally with reference to the reflector, use the operation indicator (red LED) to check the area in which the sensor is activated and install the sensor at the center of the area. Make sure that the stability indicator (green LED) is illuminated.
- 2) Use the sensitivity adjustment volume for fine-tuning when detecting thin rod-like or small objects.

(Note)

Light reflected on the object may be detected depending on the object such as glossy detection objects including stainless steel. In this case, use the sensitivity adjustment volume to prevent detection of light from the object.

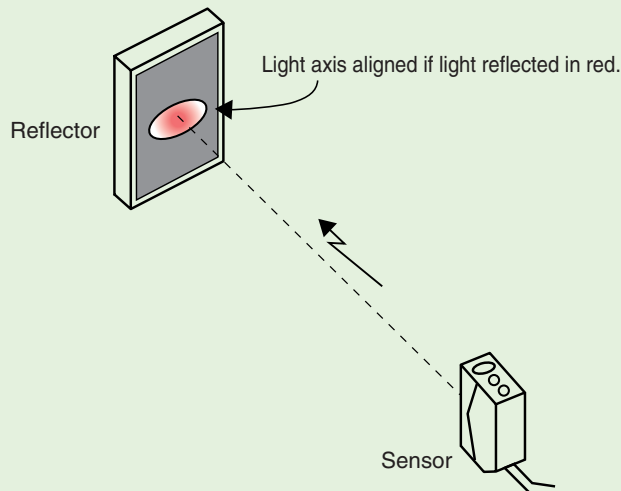

LD-S20R Series

Positioning of hybrid boards

High-precision positioning achieved with micro-spot laser beam.

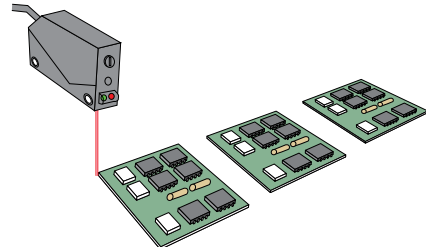

Detection of marks on corrugated cardboard boxes through narrow gap

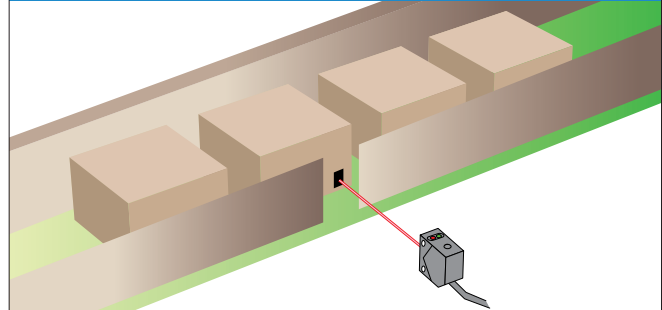

Spot position adjustment for variable-focus type sensor

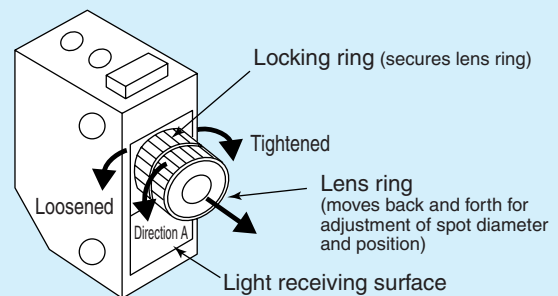

- The spot position is variable between 80 and 300 mm from the light receiving surface.
- The factory setting makes the spot diameter smallest at 300 mm from the light receiving surface. For adjusting the spot position, make sure that there is no obstacle especially in front of the receiver lens and follow the procedure below:

- 1) For viewing the spot, place a white piece of paper in front of the detection object. (Never look into the laser radiation outlet.)
- 2) (With the locking ring tightened,) turn the lens ring for adjusting the spot diameter and position while monitoring the spot on the white paper. In the figure above, turning in the direction A brings the spot position closer to the sensor. The lens ring is designed to require a certain amount of force to turn for preventing loosening, which may be felt when turning the lens.
- 3) When adjusting for a short distance, loosen the locking ring a little, make adjustment as described above and securely tighten the locking ring.
- 4) After the adjustment, mount and secure the sensor body again.

Characteristics (Typical Example)

LD-M10R series
Directional characteristics 25

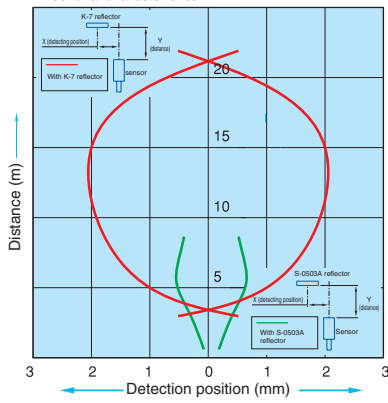

LD-M10R series
Distance-output characteristics With K-7 reflector

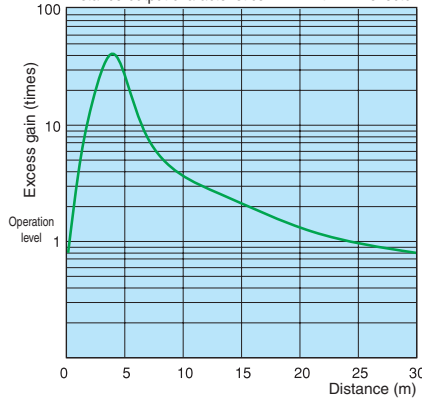

LD-M10R series
Pattern diameter 20

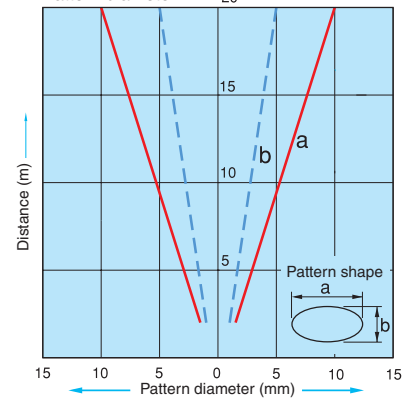

LD-M10R series
Operating angle characteristics With K-7 reflector

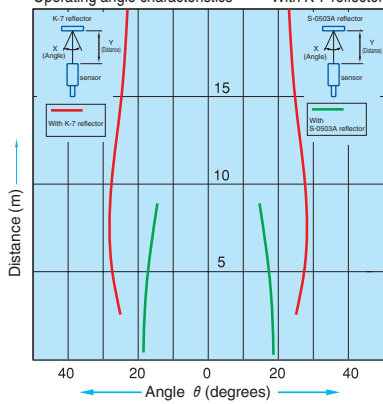

LD-S20R series
Directional characteristics 400

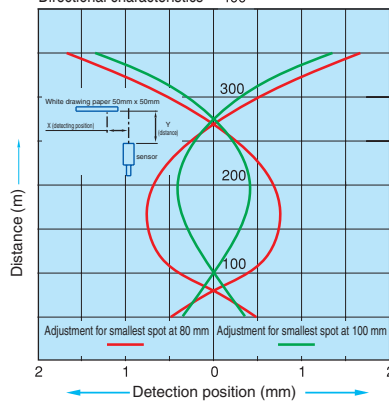

LD-S20R series
Directional characteristics 400

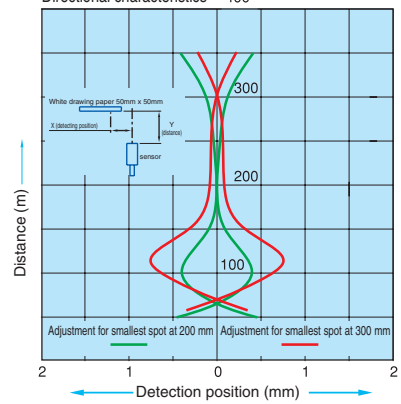

LD-S20R series
Distance-output characteristics White drawing paper 50 x 50

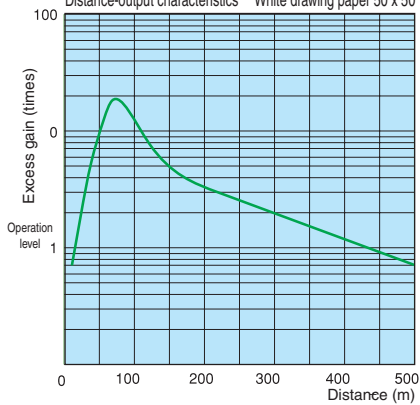

LD-S20R series
Pattern diameter Adjustment for smallest spot diameter at 80 mm

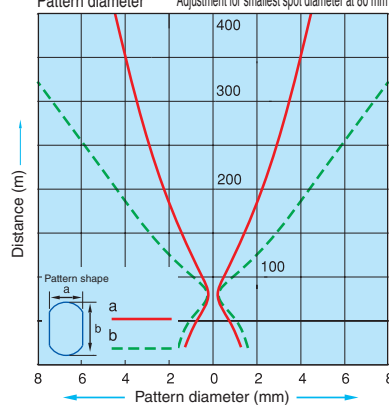

LD-S20R series
Pattern diameter Adjustment for smallest spot diameter at 100 mm

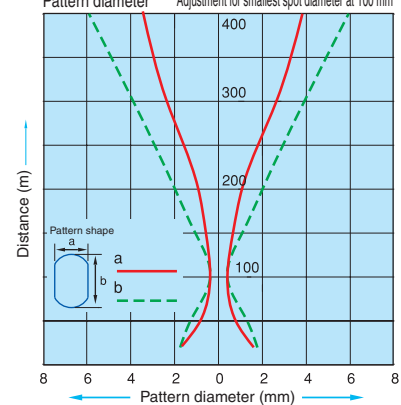

LD-S20R series
Pattern diameter Adjustment for smallest spot diameter at 200 mm

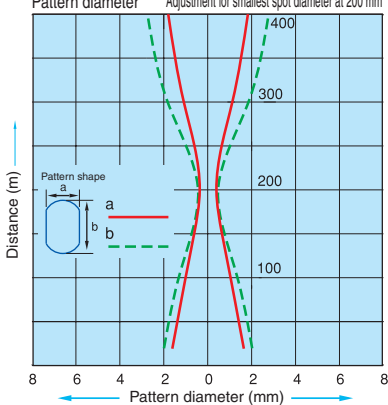

LD-S20R series
Pattern diameter Adjustment for smallest spot diameter at 300 mm

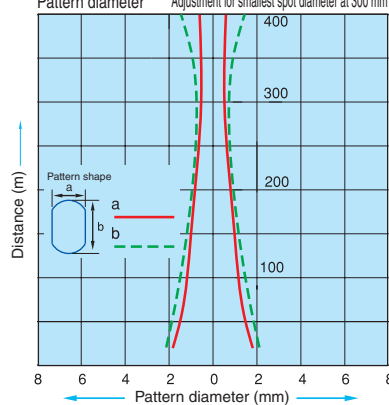

LD-M10R series LD-S20R series
Temperature characteristics (LD-S20R (PN)/LD-M10R (PN))

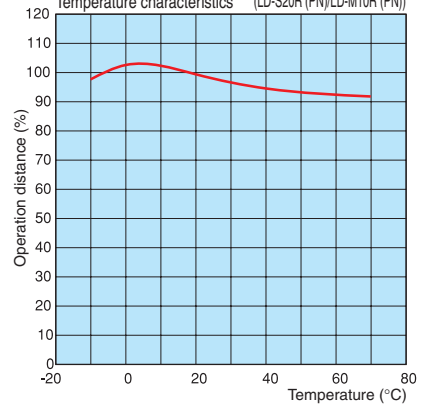

Dimensions (in mm)

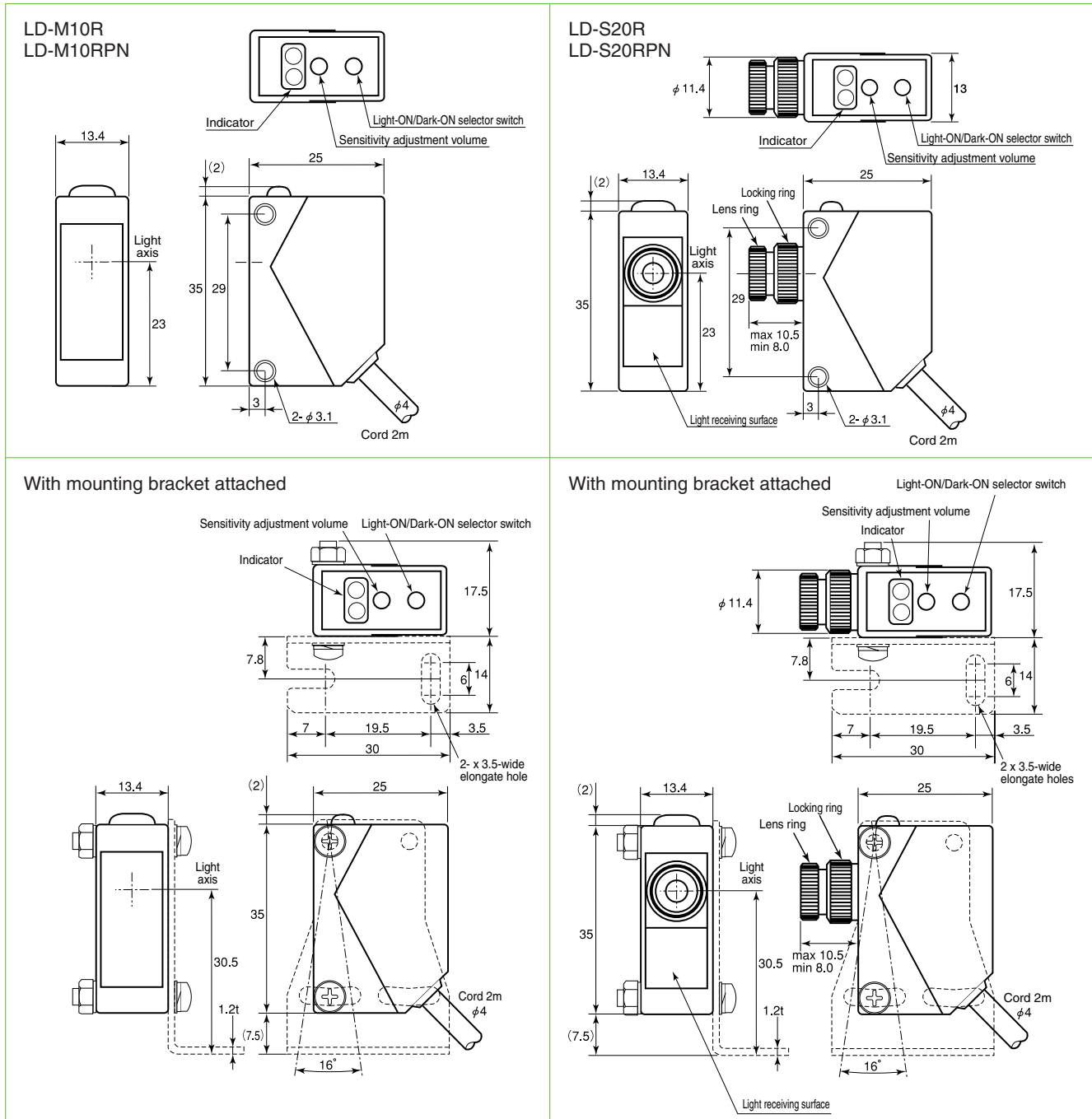

Optional Parts (in mm)

Reflector model	K-7	K-15	K-MT4	K-71	K-72	S-0503A
Detecting distance	3~15m	0.3~7m	1~7m	3~5m	1~5m	0.5~7m
Effective reflecting surface	56×36mm	36×55mm	35×35mm	32×19mm	29×8mm	24×24mm
Dimensions (in mm)						