

SS10·SS20·SS40 series Light Curtain Sensors



- Light axis interval: 10/20/40mm
- Anti Interference feature for parallel installation (M/S switching)
- Longest -in-class detecting distance of 7m (SS20/SS40 Series)

Type

Series	Detection method	Detecting distance	Light axis interval	No. of light axes	Detecting width	Set model No.	Operation mode	Detecting object	
↑ SS10	Through-beam type	2m	10mm	16	150mm	SS10-T16	<ul style="list-style-type: none"> • A/O switching A: output transistor activated when light beams of all axes are received (all axes ON) • M/S switching M: master S: slave (For prevention of interference between adjacently installed units) 	Opaque object of ϕ 17mm min	
				24	230mm	SS10-T24			
				32	310mm	SS10-T32			
				48	470mm	SS10-T48			
				64	630mm	SS10-T64			
				80	790mm	SS10-T80			
↑ SS20		7m	20mm	8	140mm	SS20-T8		<ul style="list-style-type: none"> • O: output transistor activated when light beam of any axis is received (any axis ON) 	Opaque object of ϕ 32mm min
				12	220mm	SS20-T12			
				16	300mm	SS20-T16			
				20	380mm	SS20-T20			
				24	460mm	SS20-T24			
				32	620mm	SS20-T32			
↑ SS40		40mm	4	120mm	SS40-T4			Opaque object of ϕ 52mm min	
			6	200mm	SS40-T6				
			8	280mm	SS40-T8				
			10	360mm	SS40-T10				
			12	440mm	SS40-T12				
			16	600mm	SS40-T16				
	20		760mm	SS40-T20					
	24		920mm	SS40-T24					

• Number of axes

Models with numbers of axes other than mentioned in the "Type" table are available. See "Dimensions of portions" in "Dimensions." Contact Takex for details.

• Types with unnecessary light axis disabled

Sensors with the light axes for non-detecting area disabled are available on request.

• Types allowing installation in contact with glossy surface

Products with countermeasures provided for possible faulty operation due to light from the transmitter reflected on the surrounding floor or wall going around the detection object to reach the receiver are available for all models.

Type and model

- Products with countermeasure are provided for lateral reflection: "-BH" added at the end of the standard model No. (with countermeasure for horizontal light)

SS10·SS20·SS40

Rating/Performance/Specification

	Series	SS10 series	SS20 series	SS40 series
Rating/performance	Detection method	Through-beam		
	Detecting distance	2m max.	7m max.	
	Detecting object	Opaque object of ϕ 17mm min.	Opaque object of ϕ 32mm min	Opaque object of ϕ 52mm min
	No. of light axes	(See "Type.")		
	Detecting width	(See "Type.")		
	Light axis interval	10mm	20mm	40mm
	Power supply	12-24V DC \pm 10% / Ripple 10% max.		
	Output mode	NPN open collector (*) Rating: sink current 100mA (30VDC) max.		
	Operation mode	A/O and M/S switching (with switch)		
	Response time	30ms max.	15ms max.	
Specification	Light source (wavelength)	Infrared LED (860nm)	Infrared LED (950nm)	
	Light-sensitive element	Photo transistor		
	Indicator	Transmitter: M/S indicator (red LED) / Power indicator (green LED) Receiver: Stable light reception indicator (green LED) / Operation indicator (red LED)		
	Auxiliary functions	Output short circuit protection, Anti Interference feature provided for adjacent installation		
	Switch	Transmitter: M/S mode switch (M: master / S: slave); integrated under screw on the back Receiver: Operation mode switch (A: illuminated when beams of all axes are received / O: activated when beam of any axis is received); integrated under screw on the back		
	Material	Case: aluminum / Front cover/lens: Acrylic		
	Connection	Permanently attached cord with connector (cord length: 0.2m) / Cord with connector Cord: with four 0.5mm ² cores (Outer dimension: dia.6.8)		
	Mass	About 250-800g max. (transmitter/receiver)		
	Accessory	Cord with connector (cord length: 5m), mounting brackets, operation manual		
	Notes	(*) PNP open collector output type (source current: 100mA max.) is also available.		

Environmental Specification

Environmental Specification	Ambient light	9,000lx max.
	Ambient temperature	-10 - +55°C (non-freezing)
	Ambient humidity	35 - 85%RH (non-condensing)
	Protective structure	IP66
	Vibration	10-55Hz / 1.5mm amplitude / 2 hours each in 3 directions

Optional Parts

- Cord with connector (10m)
- For transmitter: SS-H10L (gray covering)
- For receiver: SS-H10R (black covering)

Indicator Operation

	Name	Color	Description
Transmitter	Power indicator	Green	Illuminated when power is supplied
	M/S indicator	Red	Illuminated to indicate M mode Dis-illuminated to indicate S mode
Receiver	Stable light reception indicator	Green	Illuminated when the receive light intensity level is 120% or more of the operation level
	Operation indicator	Red	Illuminated when output transistor is activated A: illuminated when light beams of all axes are received O: illuminated when light beam of any axis is received

• Applicable power supply unit

PS Series

High capacity of 200mA at 12VDC

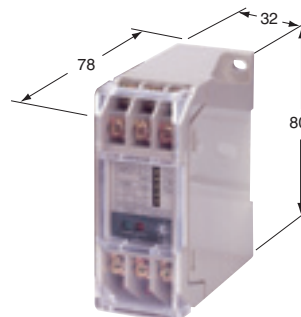

(General-purpose type)

PS3N

PS3N-SR

(Multifunctional type)

PS3F

PS3F-SR

• Current consumption by model

Model	Current consumption
SS10-T16	90mA max.
SS10-T24	103mA max.
SS10-T32	116mA max.
SS10-T48	142mA max.
SS10-T64	168mA max.
SS10-T80	194mA max.
SS10-T96	220mA max.
SS20-T8	70mA max.
SS20-T12	80mA max.
SS20-T16	90mA max.
SS20-T20	100mA max.
SS20-T24	110mA max.
SS20-T32	130mA max.
SS20-T40	150mA max.
SS20-T48	170mA max.
SS40-T4	50mA max.
SS40-T6	55mA max.
SS40-T8	60mA max.
SS40-T10	65mA max.
SS40-T12	70mA max.
SS40-T16	80mA max.
SS40-T20	90mA max.
SS40-T24	100mA max.

SS10 · SS20 · SS40

Input/Output Circuit and Connection

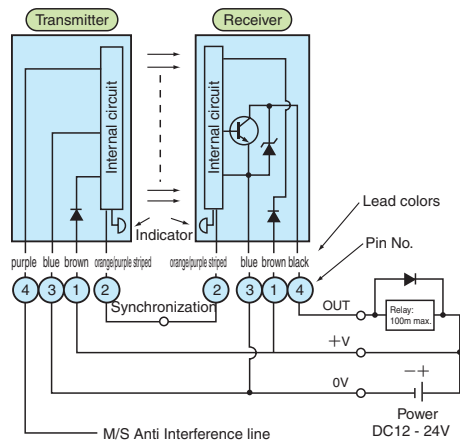

- The output transistor turns off when load short circuit or overload occurs. Check the load and turn the power back on.
- When not using the Anti Interference feature, leave the M/S Anti Interference line unconnected and ensure it will not come in contact with any other cord.

Connector pin assignment

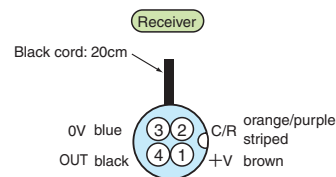
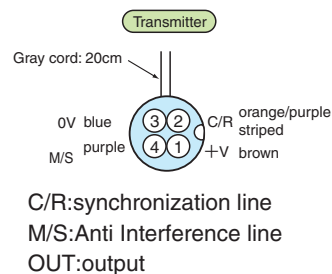

Characteristics (Typical Example)

- Parallel displacement characteristics

SS10 series

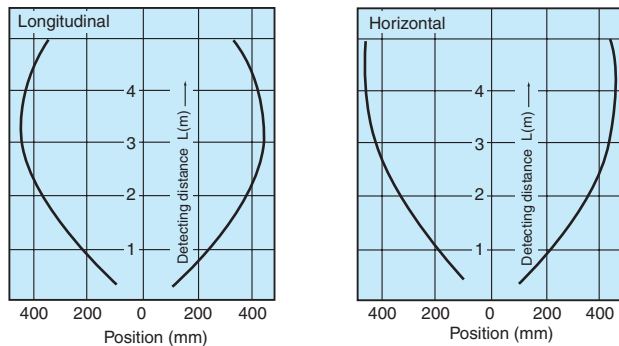

SS20/SS40 series

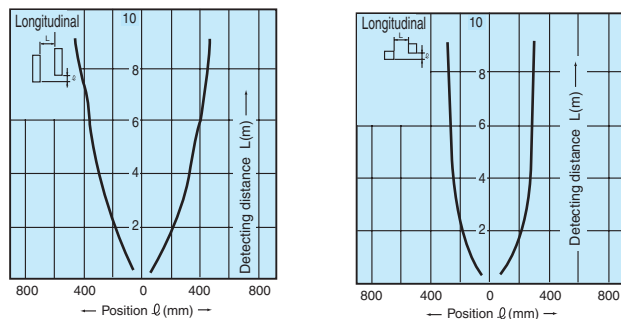

- Operating angle characteristics

SS10 series

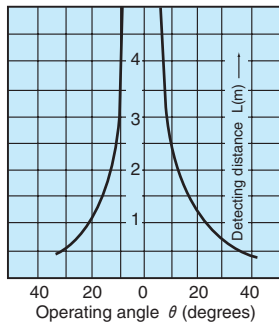

SS20/SS40 series

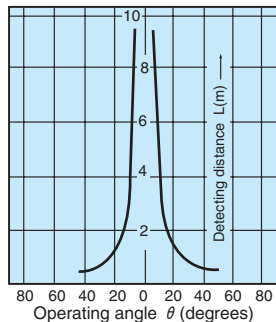

- ΔE Smallest detectable object diameter characteristics

SS10 series

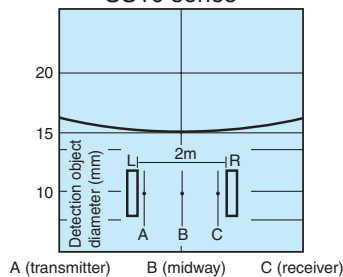

SS20 series

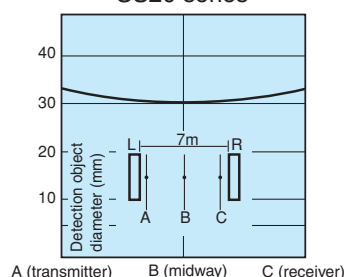

SS40 series

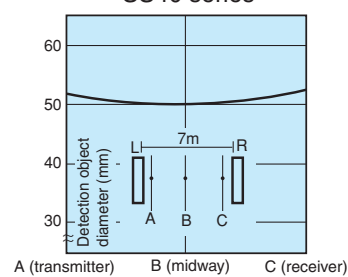

SS10 · SS20 · SS40

For Correct Use



- Be sure to follow the instructions in the operation manual provided for correct use of the product.
- This sensor cannot be used as a press safety device or other safety device for protection of human body that requires conformity to domestic or overseas standards or certification concerning protection of human body. Use for such purposes may lead to death or serious injury in the unlikely event of failure.
- This sensor is intended for detection of ingress of human body or object passing through an arbitrary point not involving protection of human body or safety.
- When using this sensor for safety purposes, ensure safe operation of the system as a whole including detection and control.

M/S (master/slave) Switching

This feature is for prevention of interference.
(With the screw on the back of the transmitter removed)

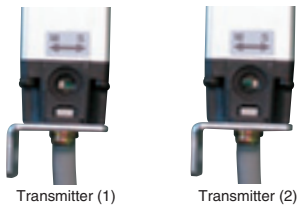

- Set the switch of either transmitter to M (master) and of the other to S (slave) and connect the Anti Interference lines of both (purple (orange) = pin No. 4) to each other. The M/S indicator of the master transmitter is illuminated (when activated) and the M/S indicator of the slave transmitter remains unilluminated. For standalone use, be sure to set the switch to M to enable the M/S indicator.

Operation Mode Switching

(With the screw on the back of the receiver removed)



- A: output transistor activated when light beams of all axes are received (all axes reception ON)
- O: output transistor activated when light beam of any axis is received (any axis reception ON)

(Factory setting: A)

Anti Interference

- When using two sets of sensors installed adjacently, connect the Anti Interference lines (purple) of Transmitters A and B with each other.
- Connect the 0 V lines of the Transmitters A and B and Receivers A and B together.
- Set the M/S (master/slave) mode switch of Transmitter A to M and of Transmitter B to S.
- When all wiring has been completed, supply power and check the operation of the M/S indicators of the transmitters:
Transmitter A (M mode): M/S indicator illuminated
Transmitter B (S mode): M/S transmitter not illuminated
- When not using Anti Interference, leave the line for this feature unconnected and ensure it will not come in contact with any other cord.

(Connection)

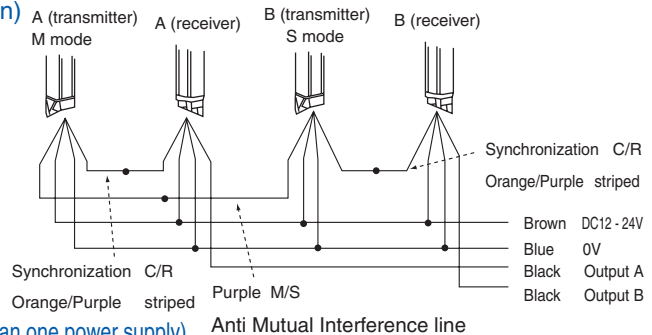

(With more than one power supply)

Connect the 0V lines of the Transmitters A and B and Receivers A and B together.

Notes on Installation

- Any reflecting object (wall, floor, machine, etc.) within the effective range between the transmitter and receiver may allow the light of the sensor to go around the detection object, which is supposed to block the light, and reach the receiver. Choose the installation location carefully.
- Make sure that the ends of the transmitter and receiver with the cord are oriented either upward or downward. The sensor does not function if the transmitter and receiver are not oriented the same way.

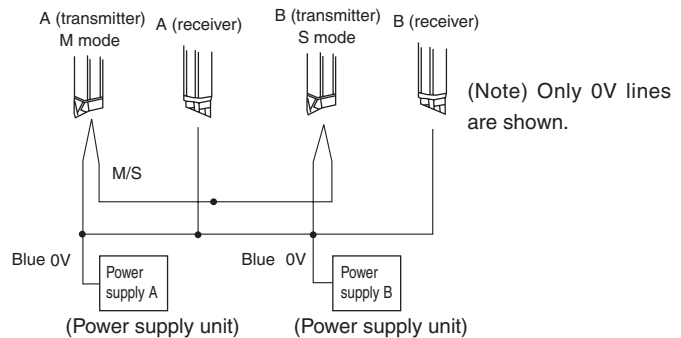
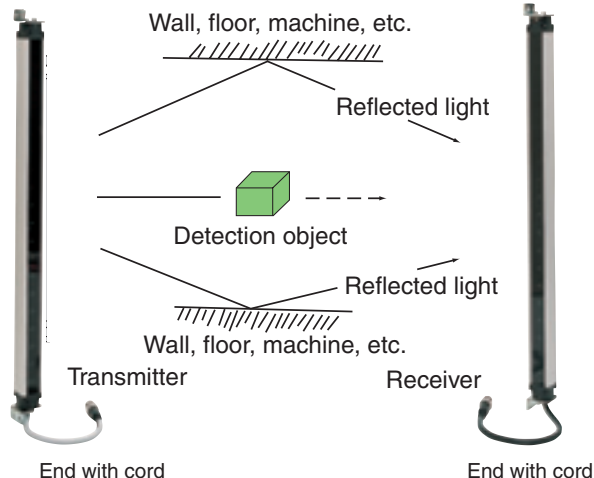

(Note) Only 0V lines are shown.

Cord Extension

C/R synchronization line (orange/purple striped)

The total length of the cord between the transmitter and receiver should be within 50 m.

M/S Anti Interference line (purple)

The total length of the cord between the transmitters of the two sets of sensors should be within 50 m.

SS10 · SS20 · SS40

Dimensions (in mm)(Only receiver is shown in the figure as an example. With transmitter, orientation of mounting bracket is reversed.)

SS10 series

CAD

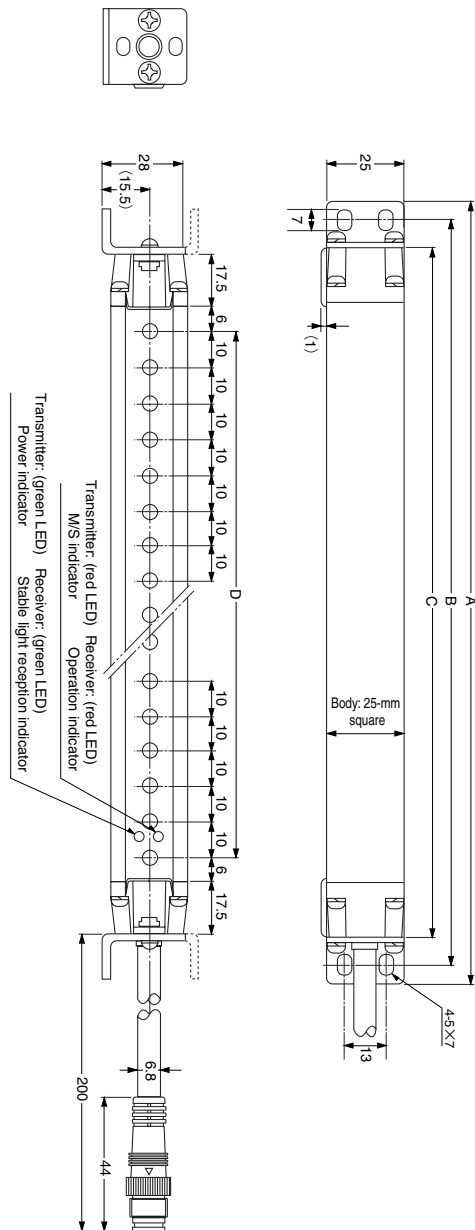

• Dimensions of portions (in mm)

Model	A	B	C	D
SS10-T16	227	215	197	150
SS10-T24	307	295	277	230
SS10-T32	387	375	357	310
SS10-T40	467	455	437	390
SS10-T48	547	535	517	470
SS10-T56	627	615	597	550
SS10-T64	707	695	677	630
SS10-T72	787	775	757	710
SS10-T80	867	855	837	790
SS10-T88	947	935	917	870
SS10-T96	1027	1015	997	950

SS20 series

CAD

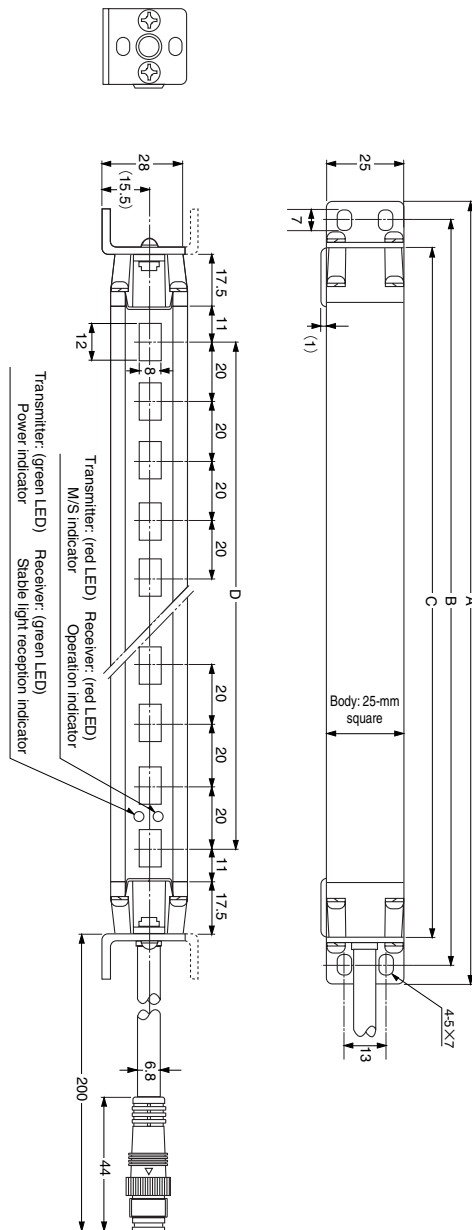

• Dimensions of portions (in mm)

Model	A	B	C	D
SS20-T8	227	215	197	140
SS20-T12	307	295	277	220
SS20-T16	387	375	357	300
SS20-T20	467	455	437	380
SS20-T24	547	535	517	460
SS20-T28	627	615	597	540
SS20-T32	707	695	677	620
SS20-T36	787	775	757	700
SS20-T40	867	855	837	780
SS20-T44	947	935	917	860
SS20-T48	1027	1015	997	940

SS10 · SS20 · SS40

Dimensions (in mm)

SS40 series

CAD



(Only receiver is shown in the figure as an example. With transmitter, orientation of mounting bracket is reversed.)

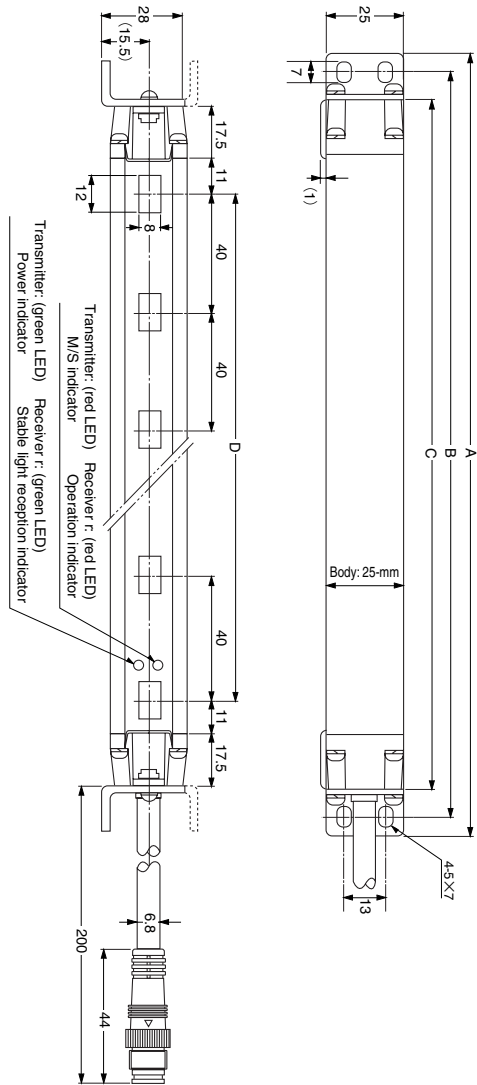

Back view (common to all sensors of the series)

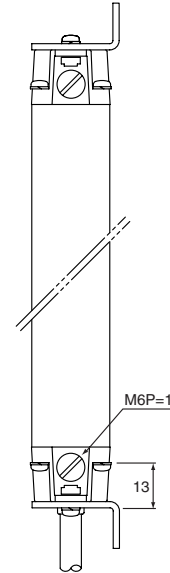

Cord with connector (accessory)

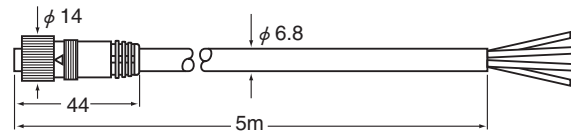

SS-H5L (covering: gray)
SS-H5R (covering: black)

Dimensions of portions

(in mm)

Model	A	B	C	D	Model	A	B	C	D
SS40-T4	207	195	177	120	SS40-T28	1167	1155	1137	1080
SS40-T6	287	275	257	200	SS40-T30	1247	1235	1217	1160
SS40-T8	367	355	337	280	SS40-T32	1327	1315	1297	1240
SS40-T10	427	435	417	360	SS40-T34	1407	1395	1377	1320
SS40-T12	527	515	497	440	SS40-T36	1487	1475	1457	1400
SS40-T14	607	595	577	520	SS40-T38	1567	1555	1537	1480
SS40-T16	687	675	657	600	SS40-T40	1647	1635	1617	1560
SS40-T18	767	755	737	680	SS40-T42	1727	1715	1697	1640
SS40-T20	847	835	817	760	SS40-T44	1807	1795	1777	1720
SS40-T22	927	915	897	840	SS40-T46	1887	1875	1857	1800
SS40-T24	1007	995	977	920	SS40-T48	1967	1955	1937	1880
SS40-T26	1087	1075	1057	1000					

