

Long distance (50 m) detection with high sensitivity  
Compact, robust and inexpensive

Operating temperature:  $-10 - +150\text{ }^{\circ}\text{C}$

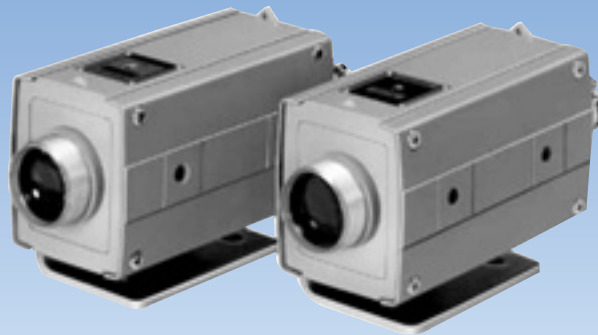

The KL(R)50 Series sensors are through-beam type CMDs that output ON-OFF signals by detecting blocking of light by the detected object that passes between the transmitter and receiver.

For receivers, relay output and voltage output types are available depending on the output mode.

## Features

- Compact, low-cost  
Streamlined design provides the smallest size and lowest cost of all water-cooled, amplifier built-in type sensors
- Robust and lightweight case  
Robust case capable of withstanding severe operating conditions such as heat, water and shock also offering light weight is employed.
- Fully prepared for external light disruption  
Unique circuitry ensures stable operation and high reliability under natural light of 300,000 lx or red-hot steel material of over 1,000 °C
- Excellent stability  
Received optical output about tenfold of operation level at detecting distance of 50 m ensures detection even with minor soiling of lens or in adverse environment.
- Optical sight convenient for alignment  
Both transmitter and receiver are provided with optical sight that facilitates light axis alignment
- Attachable airless dust hood or air purge hood  
Different types of airless dust hoods and air purge hoods are available for prevention of soiling of lens, etc.

# KL(R)50

## Rating/Performance/ Specification/ Environmental Specification

Model	KL(R)50	KL(R)50E
Detection method	Through-beam type	
Detecting distance	50m max.	
Light source	Infrared LED	
Power Supply	AC100-110V/200-220V ±10% 50/60Hz	
Power consumption	4W max	
Operation mode	Light-ON	
Output type	Relay output	Voltage output
Rating	1 transfer contact 200 VAC 0.5 A (resistance load)	DC 10V 5mA
Smallest detectable object	ø28mm	
Operating angle	5° min.	
Response time	25ms max.	5ms max.
Resistance to external light	300,000 lx	
Indication	Transmitter: power indicator (red LED); receiver: light reception indicator (red LED)	
Ambient temperature	-10 - +55 °C (150 °C max. with water-cooling)	
Ambient humidity	35 - 85%RH Max. (Non-condensing)	
Insulation resistance	500 VDC, 20 MΩ or higher (between primary side of transformer/output terminal and case)	
Dielectric withstanding	1,500 VAC for 1 minute (between primary side of transformer/output terminal and case)	
Vibration	10-55 Hz / 1.5 mm amplitude / 2 hours each in 3 direction	
Shock	500 m/s <sup>2</sup> / 2 times each in 3 directions	
Protective structure	IP66	
Case material	Aluminum die-cast	
Connection	Terminal block (cord opening ground hub)	
Mass	Transmitter: 2kg max., receiver: 2kg max.	

### • Cooling water specification

Flow rate	2 l /minute min.
Temperature	+10 - +35°C
Withstand voltage	0.29MPa

### • Air purge specification (with optional part)

Flow rate	200 l /minute min.
Withstand voltage	0.98MPa

Air not required for use of airless dust hood.

### Distance-Output Characteristics (Typical example)

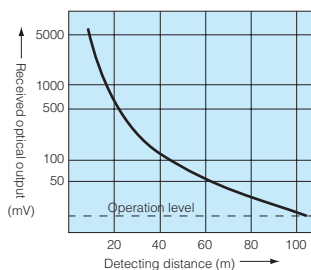

### Light Beam Width Characteristics (Typical example)

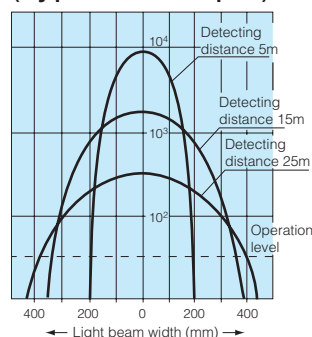

## Dimensions (in mm)

### Transmitter/receiver

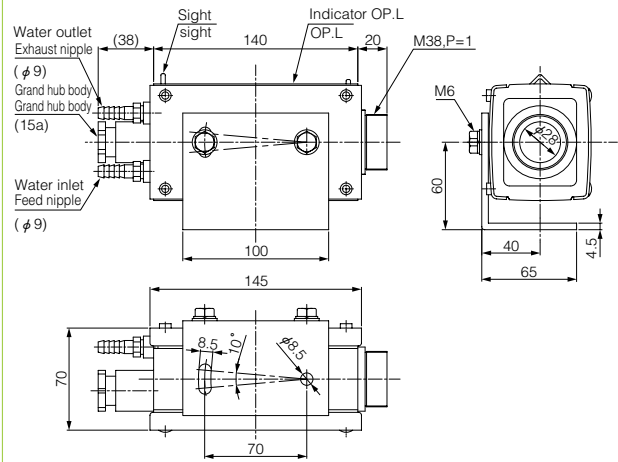

### • With Airless hood F38S Series attached

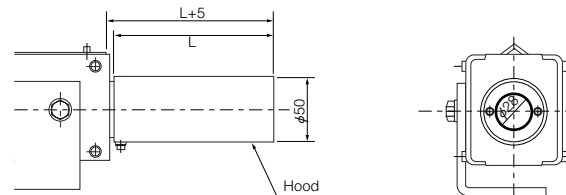

Model	Length (L)
F38S	120mm
F38S-03	300mm
F38S-04	400mm
F38S-05	500mm

### • With Airless hood F38N Series attached

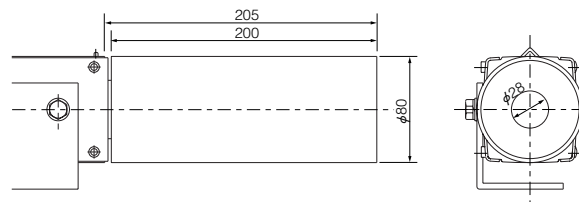

### • With air purge hood attached

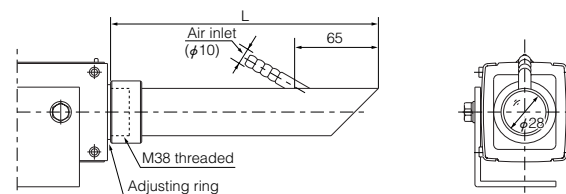

Model	Length (L)
302NC	215mm
303NC	315mm
304NC	415mm
305NC	515mm