

DA-S 100R/200 series

Self-teaching background suppression sensors

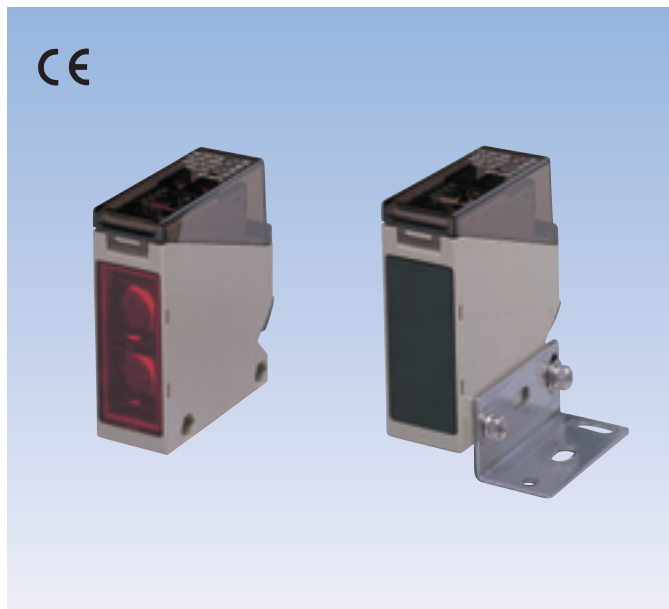



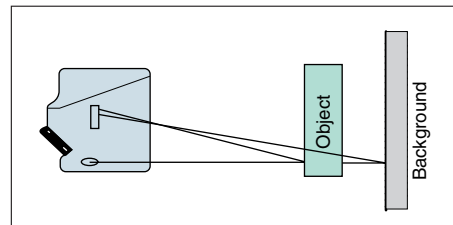

- Long detecting distance: 2 m
- Self-teaching feature
- PSD-based ranging technique employed
- Anti Interference feature

Operation less affected by change of received light intensity due to color or material of the object, soiling of sensor, etc. or light reflected on background, allowing more stable detection



■ Type

Type	Detecting distance	Model	Output mode	Power supply	Connection
Self-teaching	 0.2~1m	DA-S100RTC	NPN/PNP open collector 2 outputs	12-24VDC	Terminal block
	 0.2~2m	DA-S200TC			
	 0.2~1m	DA-S100RP	Relay output 1a	24-240V AC/DC	
	 0.2~2m	DA-S200P			

DA-S100R/200

Rating/Performance/Specification

Model		DA-S100RTC	DA-S200TC	DA-S100RP	DA-S200P	
Rating/performance	Detection method	Distance limited reflection				
	Detecting distance *	0.2-1m	0.2-2m	0.2-1m	0.2-2m	
	Range*	0.4-1m	0.4-2m	0.4-14m	0.4-2m	
	Power supply	12-24V DC $\pm 10\%$ / Ripple 10%		12-24V DC $\pm 10\%$ 50/60Hz		
	Current / power consumption	45mA max.		2.5W max.		
	Output mode	NPN/PNP open collector 2 outputs Rating: 100 mA (30 VDC) max. NPN: sink current / PNP: source current		Relay output 1a Rating: 3A 250 VAC max. resistance load 3A 30 VDC max. resistance load		
	Short circuit protection	Provided		—		
	Anti Interference	Provided				
	Operation mode	Light-ON/Dark-ON selectable				
	Timer function	On delay/off delay selectable				
		Delay time: 0-5 s				
	Response time	5ms max.		20ms max.		
	Hysteresis (Typical example)	10% max. of detecting distance				
	Light source (wavelength)	Red LED (650 nm)	Infrared LED (880 nm)	Red LED (650 nm)	Infrared LED (880 nm)	
Light-sensitive element	PSD					
Specification	Indicator	Operation indicator: orange LED Stability indicator: green LED Error indicator: red LED				
	Switch (SW)	Set button switch SET/RUN selector switch ZONE/NOR. selector switch D.ON/L.ON selector switch ON DLY/OFF DLY selector switch				
	Teaching method	Auto teaching				
	Teaching mode	Normal teaching/zone teaching				
	Material	Case	Polycarbonate			
		Lens	Acrylic	Polycarbonate	Acrylic	Polycarbonate
		Cover	Polycarbonate			
		Mounting bracket	Stainless steel (SUS304)			
	Connection	Terminal block (with M3.5 screws)				
	Mass	200 g max. (including mounting bracket)				
	Accessory	Mounting bracket (with screws), screwdriver for volume adjustment, cord securing nuts, bushings, operation manual				

*Detection object: 300×300mm white drawing paper

Environmental specification	Ambient light	Sunlight: illumination on light receiving surface 10,000 lx max. Incandescent lamp: illumination on light receiving surface 3,000 lx max.		
	Ambient temperature	-25 - +55°C (Storage: -30 - 70°C) (non-freezing)		
	Ambient humidity	35-85%RH (non-condensing)		
	Protective structure	IP67		
	Vibration	10~55 Hz / 1.5 mm amplitude / 2 hours each in 3 directions		
	Shock	500 m/s ² / 3 times each in 3 directions		
	Dielectric withstanding	1,000 VAC for 1 minute	2,000 VAC for 1 minute	
	Insulation resistance	500 VDC, 20 M Ω or higher	500 VDC, 100 M Ω or higher	

Input/Output Circuit and Connection

• Open collector output type

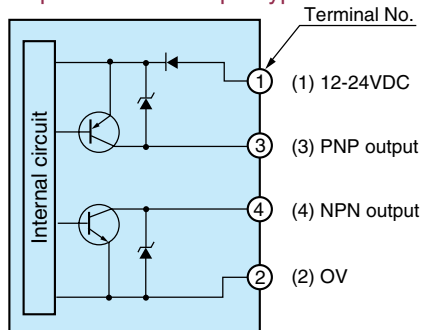

The output transistor turns off when load short circuit or overload occurs. Check the load and turn the power back on.

• Relay output type

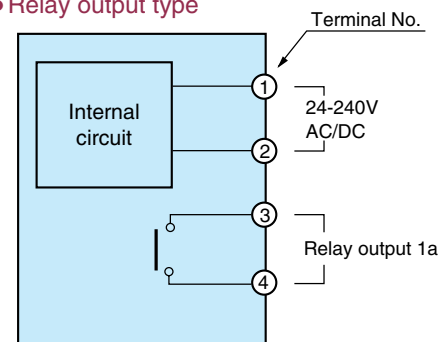

DA-S100R/200

Characteristics (Typical Example)

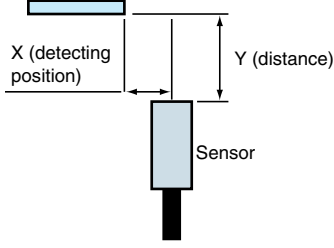
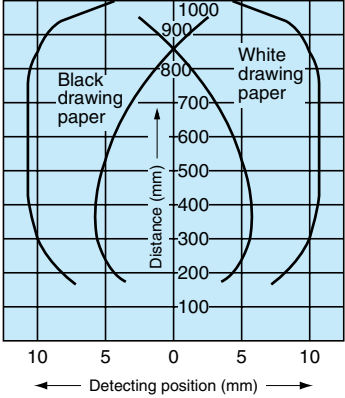
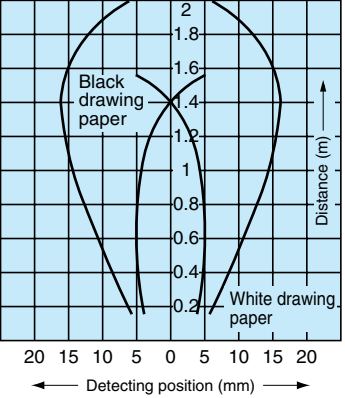
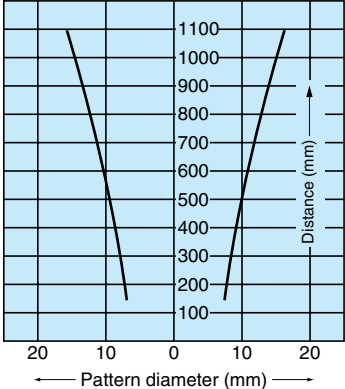
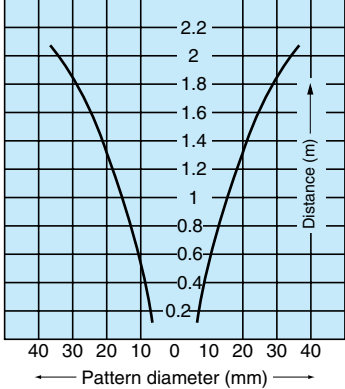
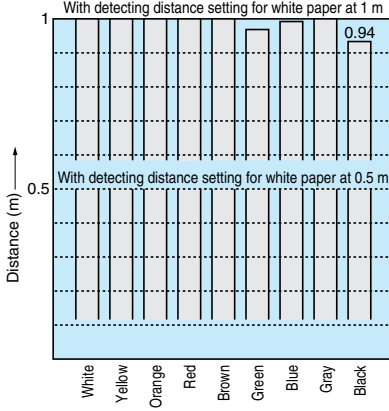
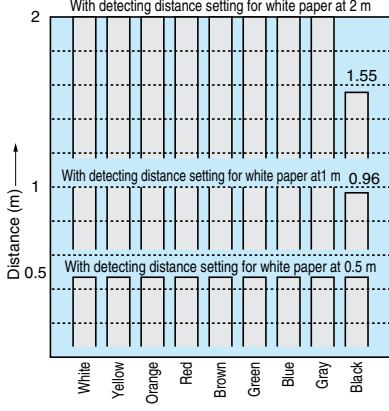
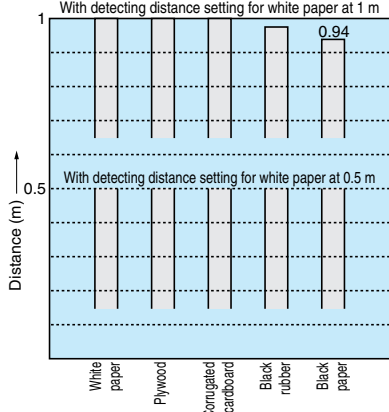
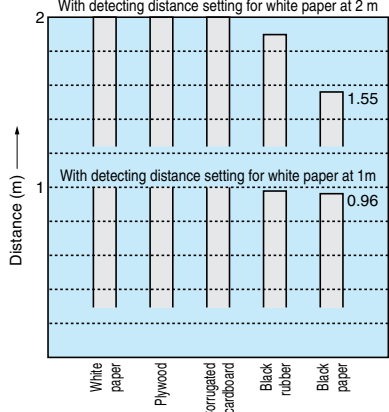
	Model DA-S100R	Model DA-S200R
<ul style="list-style-type: none"> Activation area characteristics <p>300mm×300mm drawing paper</p> 		
<ul style="list-style-type: none"> Emitted light beam diameter 		
<ul style="list-style-type: none"> Color paper detecting distance <p>170mm×170mm color paper</p>		
<ul style="list-style-type: none"> Detecting distance by material 		

For Correct Use

Be sure to follow the instructions in the operation manual provided for correct use of the product.

Panel display and functions

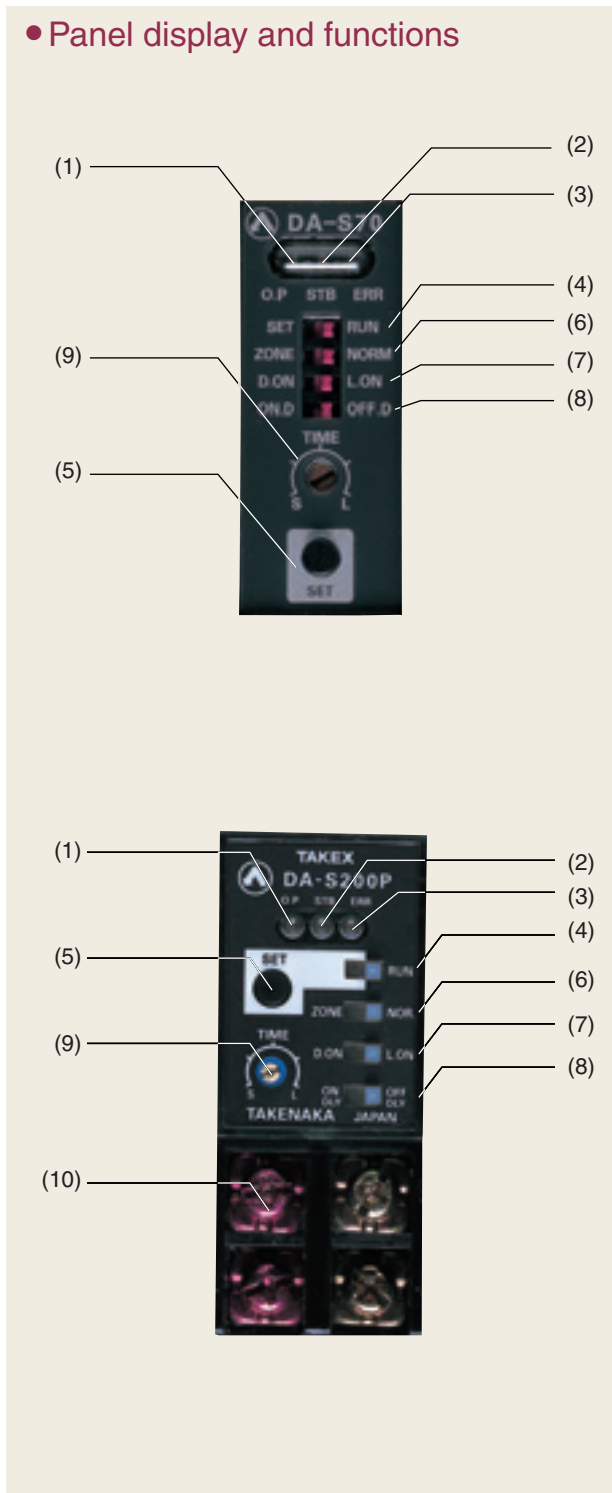

No.	<Name> Function description
(1)	<p><Operation indicator (O.P)> The orange LED is illuminated to indicate operation</p>
(2)	<p><Stability indicator (STB)> The green LED is illuminated when the received light level is in a range that allows stable activation (120% or higher of the activation level) or stable deactivation (80% or lower of the activation level). The stability indicator does not show the margin of distance but intensity of light with reference to the operation level. The distance at which the indicator is illuminated may vary depending on the reflectance of the detection object. Situations in which the stability indicator is not illuminated may cause unstable detection.</p>
(3)	<p><Error indicator (ERR)> The Red LED is illuminated or flashes if any error occurs during teaching.</p>
(4)	<p><SET/RUN selector switch> [SET] setting allows teaching (distance setting). [RUN] setting activates the sensor at the distance stored with [SET].</p>
(5)	<p><Set button switch (SET)> Pressing the Set button with the selector switch at [SET] enables distance teaching.</p>
(6)	<p><ZONE/NOR. selector switch> [ZONE] setting enables operation in the range between the 2 teaching points (set distance). [NOR] setting enables operation between the teaching point (set distance) and the sensor.</p>
(7)	<p><D.ON/L.ON selector switch> [D.ON] setting enables the following operation: Activated outside of the detecting range in the ZONE mode. Activated when a certain amount of light is not receive in the NOR mode. [L.ON] setting enables the following operation: Activated in the detecting range in the ZONE mode. Activated when a certain amount of light is received in the NOR mode.</p>
(8)	<p><ON DLY/OFF DLY selector switch> [ON DLY] setting enables the on-delay timer. [OFF DLY] setting enables the off-delay timer.</p>
(9)	<p><Delay time adjustment volume (TIME)> MIN(S) setting overrides the delay and enables normal on/off operation.</p>
(10)	<p><Terminal block> For the DA-S100R/200 Series only.</p>

Teaching pattern and detection setting

Four teaching patterns are available:

- (1) NOR mode 1-point teaching
- (2) NOR mode 2-point teaching
- (3) ZONE mode teaching
- (4) Maximum distance (default) teaching

The following section provides applications, setting procedure, sensor operation and notes.

(1) NOR mode 1-point teaching and applications

This type of setting is suitable for detection in which it is difficult to provide the detection object at a specific place and the background (reflecting object such as wall and conveyor) is within the sensor detecting range.

Applications: detection of object on conveyor or on this side of the background

Setting procedure

- 1) Set the ZONE/NOR selector switch to [NOR].
- 2) Set the SET/RUN selector switch to [SET].

The operation indicator (orange LED) starts flashing.



- 3) Press the SET button with the background only.

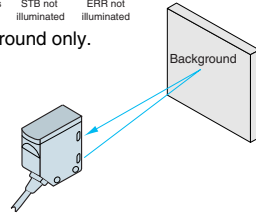

The stability indicator (green LED) is illuminated when the SET button is pressed.



Release the SET button when the stability indicator (green LED) is illuminated.

Note: Holding down the button enables the maximum distance teaching mode.

When the SET button is released, the stability indicator (green LED) stays illuminated and the operation indicator (orange LED) starts flashing.



Teaching (distance setting) is complete.

- 4) Set the SET/RUN selector switch to [RUN].

Operation

- The detecting range is within the set detecting distance.
- The set activation position is within about 20% on this side of the background.
- Set the operation mode by selecting between L.ON and D.ON.

(2) NOR mode 2-point teaching and applications

Use the actual detection object for setting the detecting distance. This type of setting is intended for detection not susceptible to the background.

Applications: detection of object on conveyor, distinction between different heights or positions of objects

Setting procedure

- 1) Set the ZONE/NOR selector switch to [NOR].
- 2) Set the SET/RUN selector switch to [SET].



The operation indicator (orange LED) starts flashing.



- 3) Provide the detection object at a place for distance setting with a margin taken into consideration and press the SET button twice.

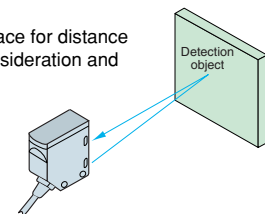

The stability indicator (green LED) is illuminated when the SET button is pressed for the first and second times alike.

Release the SET button when the stability indicator (green LED) is illuminated.

Note: Holding down the button enables the maximum distance teaching mode.

When the SET button is released, the stability indicator (green LED) stays illuminated and the operation indicator (orange LED) starts flashing.



Pressing the SET button twice sets the distance.

- 4) Set the SET/RUN selector switch to [RUN].

Operation

- The detecting range is within the set detecting distance.
- The activation position is $\pm 5\%$ with reference to the position of the detection object used for the teaching.
- Set the operation mode by selecting between L.ON and D.ON.

Notes

- When the SET button is pressed 3 or more times, the last two teaching operations overrides the previous operations for teaching.
- If the SET button is pressed at different positions for the first and second teaching operations, the activation position is set midway between the distances set by the first and second teaching operations.

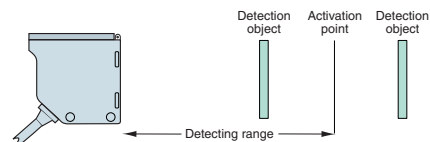

The detecting range is between the activation point and the sensor.

(3) ZONE mode teaching and applications

A detection zone is set within the sensor detecting distance.
Applications: detection of object in a range between two points at different distances from the sensor disregarding the farther and nearer ranges or provision of a non-detection zone within the detecting distance

Setting procedure

- 1) Set the ZONE/NOR selector switch to [ZONE].
- 2) Set the SET/RUN selector switch to [SET].
The operation indicator (orange LED) starts flashing.

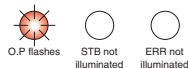

- 3) Provide the detection object at a distance on the farther boundary of the intended detecting range and press the SET button.

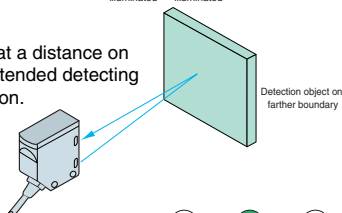

The stability indicator (green LED) is illuminated when the SET button is pressed.



When the SET button is released, the stability indicator (green LED) stays illuminated and the operation indicator (orange LED) starts flashing.



The first teaching point has been set.

- 4) Provide the detection object at a distance on the closer boundary of the intended detecting range and press the SET button.

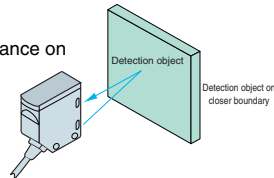

While the SET button is pressed, the operation indicator (orange LED) is not illuminated and only the stability indicator (green LED) is illuminated.



When the SET button is released, again the stability indicator (green LED) stays illuminated and the operation indicator (orange LED) starts flashing.



The second teaching point has been set.

(Teaching may be started at either the farther or closer boundary.)

- 5) Set the SET/RUN selector switch to [RUN].

Operation

- The detecting range is the limited zone between the farther and closer boundaries.

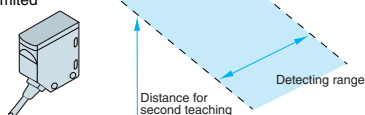

- L.ON/D.ON setting and operation
L.ON : activated within the detecting range
D.ON : activated outside of the detecting range

Notes

- Set the closer boundary at within 80% of the farther boundary setting.
- When the SET button is pressed 3 or more times, the last two teaching operations overrides the previous operations for teaching.

(4) Maximum distance (default setting) teaching

The sensitivity is set at maximum for detection.
Applications: extension of the detecting distance as much as possible to make the most of the maximum detecting distance of the sensor when no background object (reflecting object such as wall and conveyor) is present

Setting procedure

- 1) Set the ZONE/NOR selector switch to [NOR].
- 2) Set the SET/RUN selector switch to [SET].
The operation indicator (orange LED) starts flashing.



- 3) Press and hold down the SET button for 3 seconds or longer.

- (1) When the button has been held down for 1.5 seconds, the operation indicator (orange LED) stops flashing and stays illuminated.



- (2) When the button has been held down for another 1.5 seconds, the stability indicator (green LED) is illuminated. Release the SET button.



- (3) The setting is complete.

- (4) Set the SET/RUN selector switch to [RUN].

Operation

- The maximum detecting distance of the sensor is enabled for detection of objects.

Note

- The detecting distance may be shorter than the maximum allowable teaching distance with the background or object present.

Teaching error

The error indicator [ERR] (red LED) is illuminated or flashes if any error occurs during teaching. The error is reset when successful teaching has been completed.

○ NOR mode teaching

- Possible cause: no detection object present or insufficient light reception
- Indicator operation

• SET button pressed			• SET button released		
O.P. illuminated	STB not illuminated	ERR illuminated	O.P. flashes	STB not illuminated	ERR illuminated

(Note: Holding down the button enables the maximum distance teaching mode.)

- Correction: Adjust the distance between the sensor and the detection object or background and perform teaching operation (distance setting) again.

○ ZONE mode teaching

- Possible cause: no detection object present, insufficient light reception or insufficient interval between 2 points
- Indicator operation

• SET button pressed			• SET button released		
O.P. illuminated	STB not illuminated	ERR illuminated	O.P. flashes	STB not illuminated	ERR flashes

- Correction: Adjust the distance between the sensor and the detection object or background or between 2 points and perform teaching operation (distance setting) again.

DA-S

For Correct Use

Be sure to follow the instructions in the operation manual provided for correct use of the product.

Notes on installation and countermeasures

	Notes	Countermeasures
	<p>Some limitations apply regarding the orientation of the sensor and direction of the movement of the detection object. However, up-down movement is allowed within the set detecting distance.</p>	<p>Note the installation and direction of movement of the object as shown in the figure when installing the sensor.</p>
	<p>In the NOR mode, faulty operation may occur when the object moves outside of the sensor detecting range (farther boundary).</p>	<p>Provide background (wall or object not to be detected) outside of the detecting range (farther boundary) for preventing faulty operation.</p>
	<p>In the ZONE mode, faulty operation may occur when the object passes outside of the sensor detecting range (closer boundary) if the farther boundary of the detecting zone is set close to the background (wall or object not to be detected).</p>	<p>Remove the background object or use the on-delay timer.</p>
	<p>Detection may be unstable if any glossy floor or conveyor is present under the sensor.</p>	<p>Mount the sensor at an angle or leave a gap of 200 mm or longer between the sensor and the object underneath.</p>
	<p>Faulty operation may be caused by a slight angle variation when any mirror-like or glossy object (in the background) is present on the side of the farther boundary.</p>	<p>Mount the sensor at an angle and check the operation with the detection object.</p>

- A dead zone may be generated on the closer side depending on the type of detecting object.
- Ensure that no strong beam of sunlight, fluorescent or incandescent lamp, etc. enters the operating range of the sensor.



- Do not use the sensor for detection for protection of human body.
- For safety applications, ensure safe operation of the detection and control system as a whole.
- This product is not explosion proof.

Dimensions (in mm)

Model	
DA-S40R	DA-S70
DA-S40RPN	DA-S70PN
DA-S40R-J	DA-S70-J

Model	
DA-S100RTC	DA-S200TC
DA-S100RP	DA-S200P

Permanently attached cord type

CAD

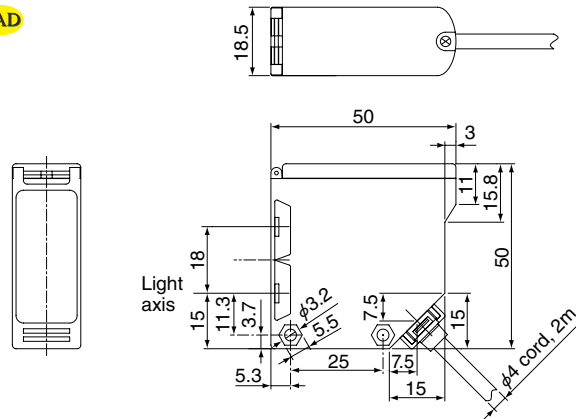

With mounting bracket attached

CAD

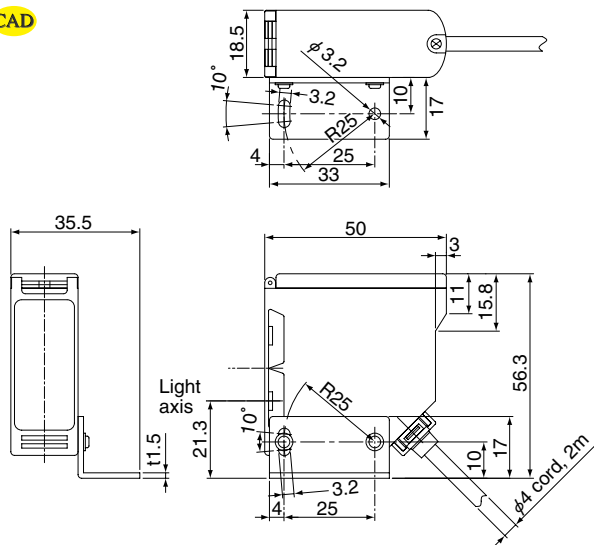

M8 connector type

(Mounting bracket is not provided with the connector type.)

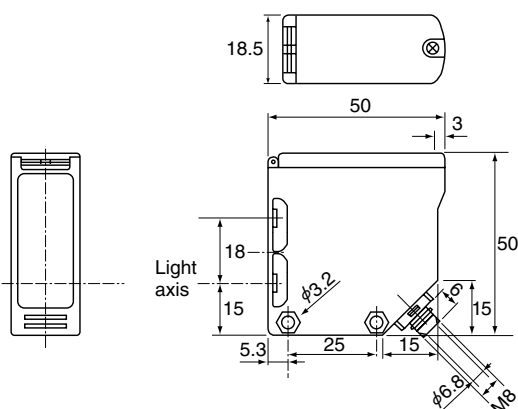

Body

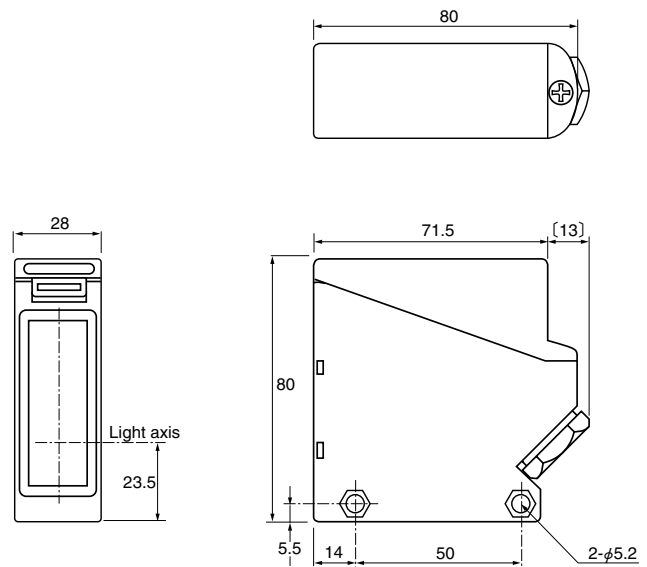

With mounting bracket attached

