





- Capable of long-distance measurement
- Built-in teaching function for simple operation and highly-accurate measurement
  - Integrated temperature sensor for stable measurement
  - Anti Interference feature
  - High resolution 12-bit D/A converter
  - Attachments available for wider range of applications (wave guide/wave reflector)

## Type

Measuring method	Measuring range	Model	Operation mode	Output mode
Reflective type	 0.1~1m	<b>USA-S1AN</b>	Proportional output	Analog output
	 0.4~3m	<b>USA-S3AN</b>		

## Attachments (applicable to USA-S1AN)

Type	Measuring range with attachment provided	Model	Shape
Wave guide	Depends on the length of pipe	<b>USA-WG08FS</b>	Straight
		<b>USA-WG08FL</b>	Angled
Wave reflector	 65~965mm	<b>USA-WR</b>	Side-on in direction of detection

## Optional Parts

Type	Model	Shape, etc.
Cord with connector	<b>FAC-D4R2S</b>	4-core M12 straight, 2 m
	<b>FAC-D4R5S</b>	4-core M12 straight, 5 m

## Rating/Performance/Specification

Model	USA-S1AN	USA-S3AN
Detecting distance	0.1-1m	0.4-3m
Detection object	100x100mm (sample object: 2-mm thick aluminum plate)	
Power supply	12-24V DC $\pm 10\%$ / Ripple (p-p) 10% max.	
Power consumption	1.3W max.	
Response speed (standalone use)	150ms max.	300ms max.
Analog output	4-20 mA current output (reverse output available with SET button); see *3 for voltage output	
Minimum resolution *1	0.9mm (0.1%F.S.)	2.6mm (0.1%F.S.)
Linearity	$\pm 1\%$ F.S.	
Temperature characteristics	$\pm 1\%$ of F.S. max. with reference to output at 23 °C between -10 and +55 °C ( $\pm 0.03\%$ of F.S./ °C max.)	
Applicable load	0-250 $\Omega$	
Ultrasonic frequency	About 200 kHz	About 75 kHz
Indicator	RUN: (green) 4mA: (red) mid (orange) 20mA (green)	
Teaching system	Teaching: distance setting, output inversion (with SET button)	
Connection	Connector (M12) *2	
Mass	Approx. 150 g	Approx. 300 g
Protective feature	Output short circuit protection, power supply output protection against reverse connection	
Material	Case: brass (nickel plated) / Detection side: nylon, silicon, glass epoxy resin	

\*1 Value applicable about 15 minutes after power-up. Output may be slightly fluctuated by external disturbance, etc.

\*2 Cord with M12 connector is separately available.

\*3 May be converted into voltage output (1-5 V) with the resistor (250  $\Omega$ ) provided.

## Environmental Specification

Ambient temperature	-10 - +55 °C (non-freezing)
Ambient humidity	35-85%RH (non-condensing)
Protective structure	IP67 (no drops of water allowed on head)
Vibration	10-55 Hz / 1.5 mm amplitude / 2 hours each in 3 directions
Shock	500 m/s <sup>2</sup> / 3 times each in 3 directions (ultrasonic element excluded)
Dielectric withstanding	1000VAC 50/60Hz for 1 minute
Insulation resistance	500 VDC, 50 M $\Omega$ or higher

- Applicable comparator



(ANP Series)

## Panel and Indicators

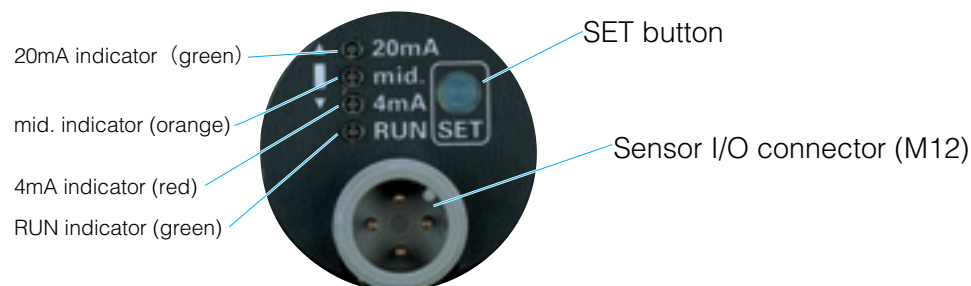

Name	Color	Operation
20 mA indicator	Green	Illuminated when output current is about 20 mA or larger
mid. indicator	Orange	Illuminated when detection object is within measuring range
4 mA indicator	Red	Illuminated when output current is about 4 mA or smaller
RUN indicator	Green	Illuminated while power is supplied

## Input/Output Circuit and Connection

(For measurement)

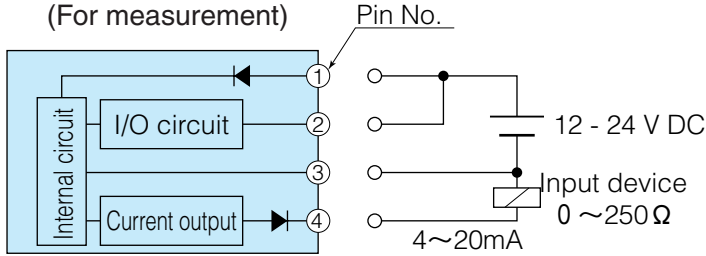

Cord with M12 connector

Pin arrangement	Pin No.	Description	Core colors
	①	Power supply (+)	Brown
	②	I/O	White
	③	0V	Blue
	④	Current output	Black

## Characteristics (Typical Example)

- Detecting area characteristics (flat plate)

USA-S1AN

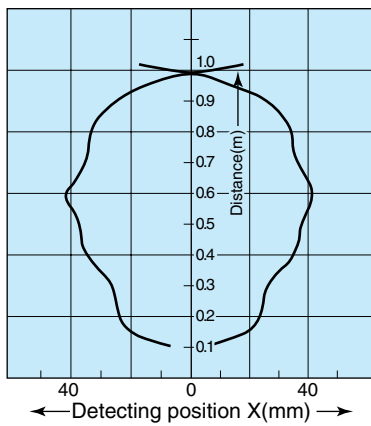

USA-S3AN

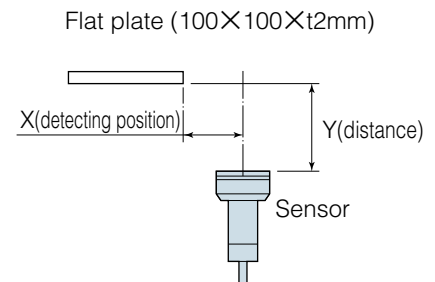
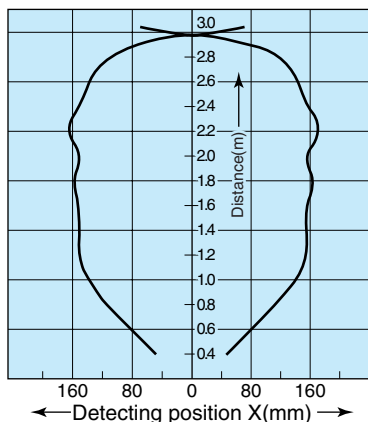

- Detecting area characteristics (round bar)

USA-S1AN

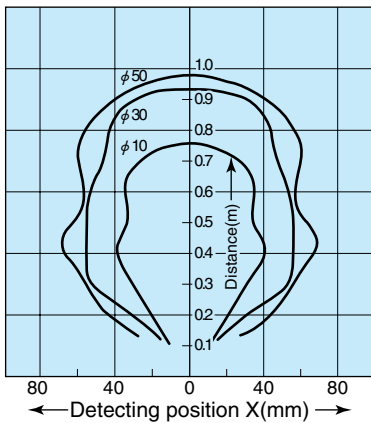

USA-S3AN

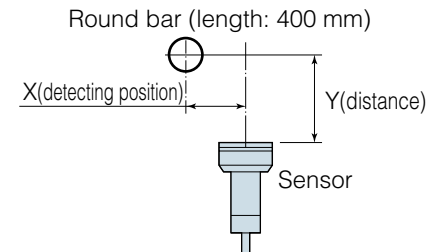
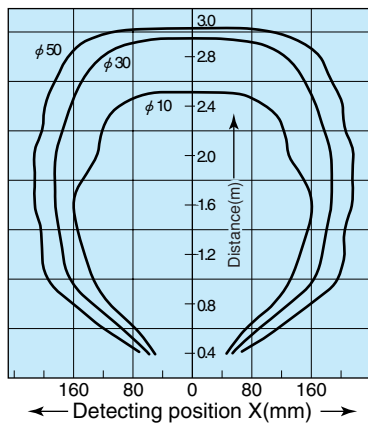

- Current consumption characteristics

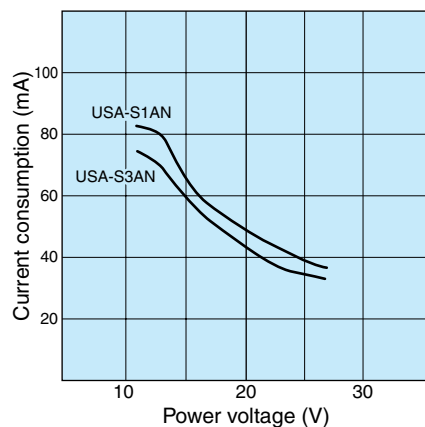

### Surface temperature of detection object

Ultrasonic waves reflected on a surface at a temperature above 100 °C may be extremely low. Be sure to test the operation before putting the sensor to use.

## For Correct Use

Be sure to follow the instructions in the operation manual provided for correct use of the product.

### Teaching procedure

#### • Range setting

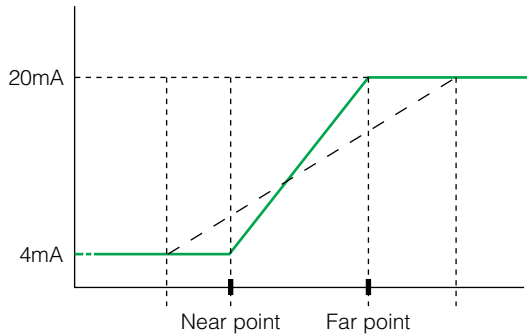

Current output between 4-20 mA is available between arbitrary 2 points within the measuring range.

(The factory setting is maximum measuring range.)

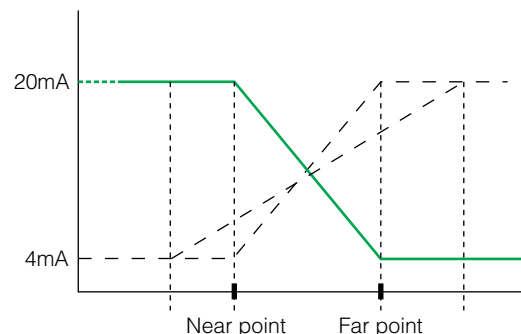

#### • Incremental/decremental mode switching

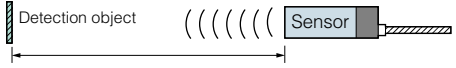
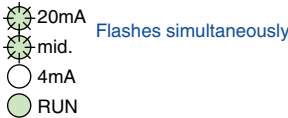
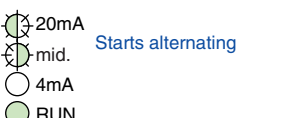
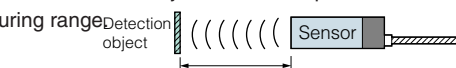
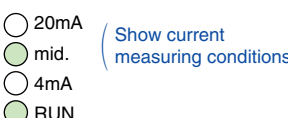

The operation can be switched between the modes in which output current increases and decreases according to the distance.

(The factory setting is the incremental mode.)

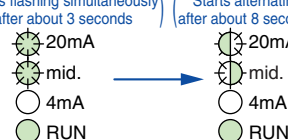
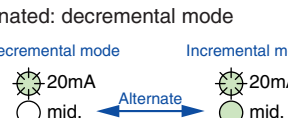
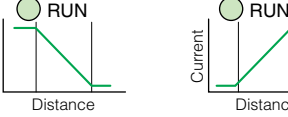
Procedure	Operation and indicator
①	Provide the detection object at the far point of the measuring range. 
②	Press and hold down the SET button for about 3 seconds (3-6 seconds) 
③	Release the SET button. 
④	Provide the detection object at the near point of the measuring range. 
⑤	Press the SET button once (0.5 seconds min.). 
Completed	The setting has been made for output between 4 and 20 mA for near and far points respectively.

Procedure	Operation and indicator
①	Press and hold down the SET button for about 8 seconds (8-12 seconds). 
②	Release the SET button. The mid (orange) indicator turns on and off every time the SET button is pressed. mid (orange) illuminated: incremental mode mid (orange) not illuminated: decremental mode 
③	The mid (orange) indicator turns on and off every time the SET button is pressed. mid (orange) illuminated: incremental mode mid (orange) not illuminated: decremental mode 
Completed	The 20 mA (green) indicator starts flashing quickly about 4 seconds after the last switch operation and, about 2 seconds later, the mode is determined. 



- Do not use the sensor for protection of human body.
- For safety applications, ensure safe operation of the detection and control system as a whole.



## External teaching

Teaching operation may be performed by using the external switch (Pin (2) I/O line) instead of the SET button on the sensor unit.

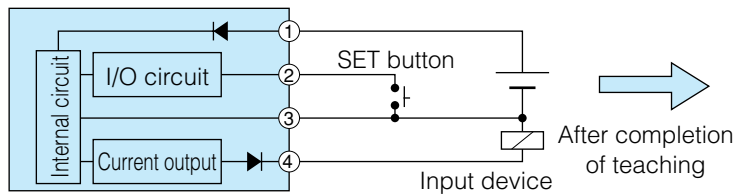

Short-circuit Pin (2)(I/O) to Pin (3) (GND) for use as teaching switch wiring.

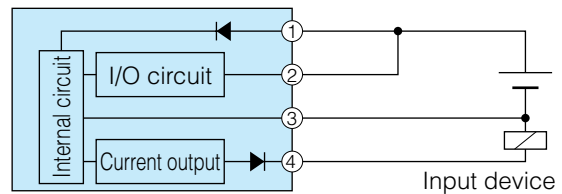

When teaching has been completed, connect Pin (2) to Pin (1) (+). Leaving the Pin (2) line

## Installation

Be sure to use the nuts provided to install the sensor and tighten with a torque of 15 N·m max.

## Cord Extension

To extend the cord, use wires of at least 0.3 mm<sup>2</sup> and limit the length to within 300 m.

When the wiring is 5 m or longer, separate the GND lines for output and power supply at a point within 5 m.

## Dimensions (in mm)

### USA-S1AN

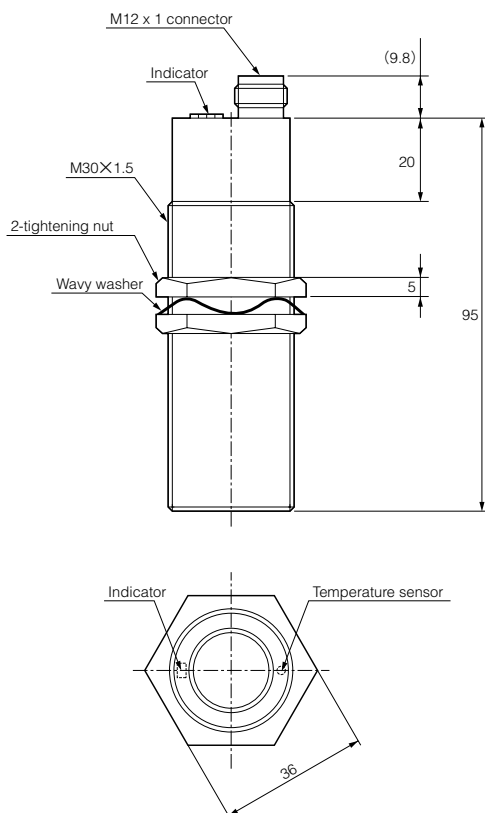

### USA-S3AN

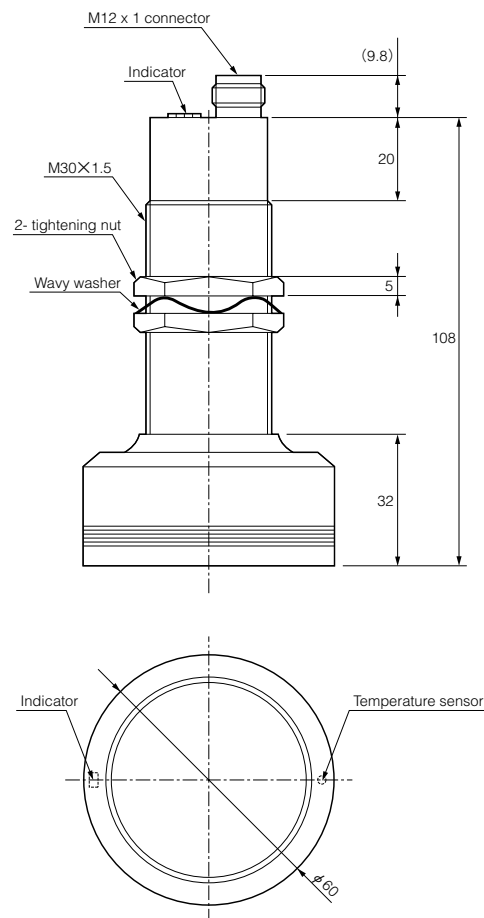

### FAC-D4R2S (L:2m) FAC-D4R5S (L:5m)

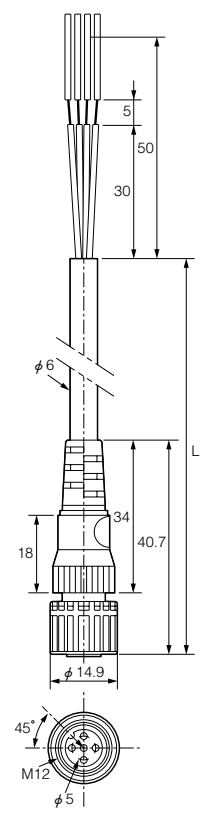

## Attachment

Produce name: wave guide

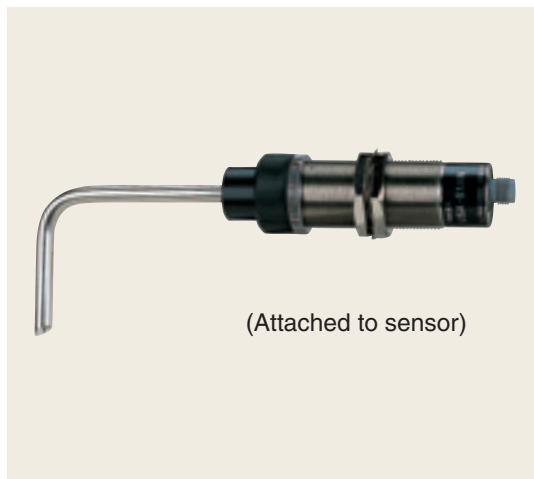

- Offers flexibility of detection head
- Small angle of aperture for pinpoint detection
- No dead zone and capable of close proximity detection
- Free-cutting pipe counteracts installation space restrictions

Model	Straight			Angled		
	USA-WG08FS			USA-WG08FL		
Detecting distance(*)	0-300mm <small>(with pipe length 100 mm)</small>	0-200mm <small>(with pipe length 150 mm)</small>	0-100mm <small>(with pipe length 200 mm)</small>	0-100mm <small>(with pipe length 100 mm)</small>	0-75mm <small>(with pipe length 150 mm)</small>	0-50mm <small>(with pipe length 200 mm)</small>
	(*) Detecting distance depends on the length of pipe.					
Pipe length	Pipe can be cut freely on the sensor side.					
Standard detection object	100x100mm t=2mm aluminum plate					
Material	Pipe: copper (nickel plated) Clamp: polyacetal resin Locking ring: brass (nickel plated)					
Applicable sensor	USA-S1AN					

## Detection area characteristics (Typical Example)

Flat plate detection (100x100mm)

Model USA-WG08FS (straight)

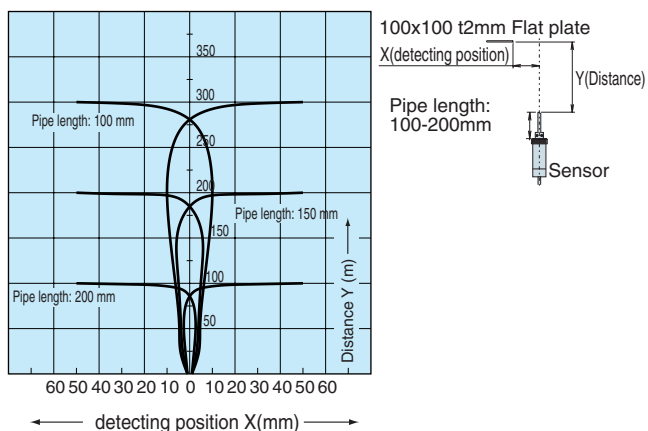

Model USA-WG08FS (Angled)

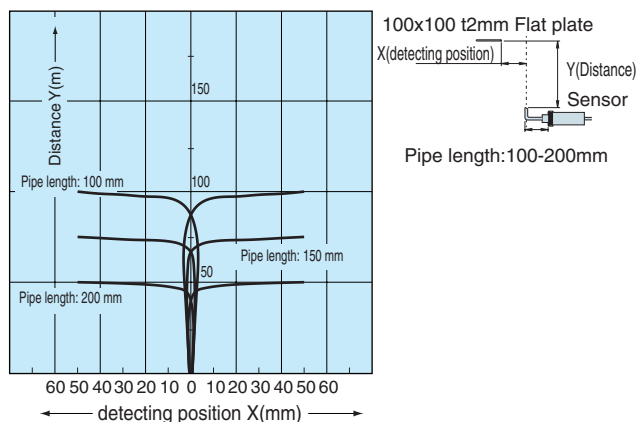

## Dimensions (in mm)

Model USA-WG08FS

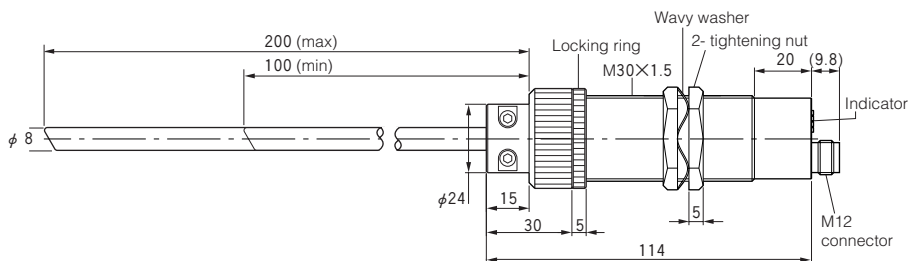
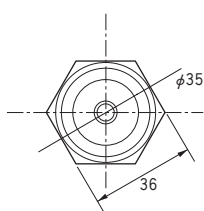

Model USA-WG08FL

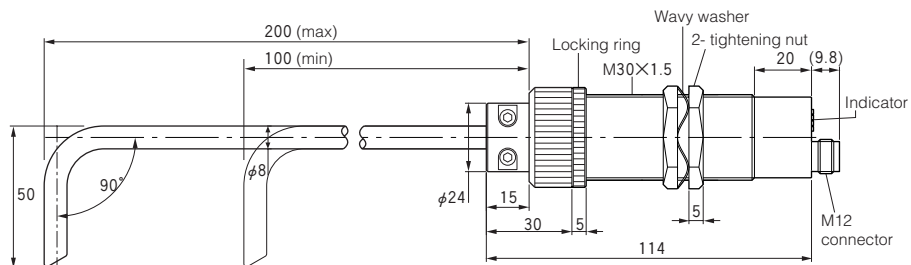
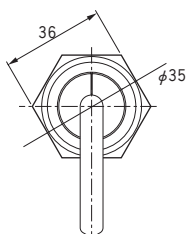

(Attached to sensor)

## Attachment

Produce name: wave reflector



- Side-on attachment for deflecting the detection angle by 90°
- Eliminates installation space restrictions

Model	USA-WR
Detecting distance	65-965mm
Detection object	100x100mm t=2mm aluminum plate
Material	Body: polyacetal resin Locking ring: brass (nickel plated)
Applicable sensor	USA-S1AN

## Detection area characteristics (Typical Example)

Flat plate detection (100x100mm)

Model USA-WR

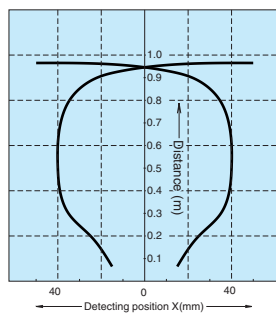
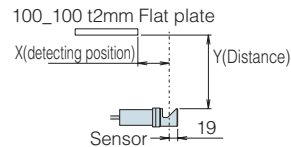
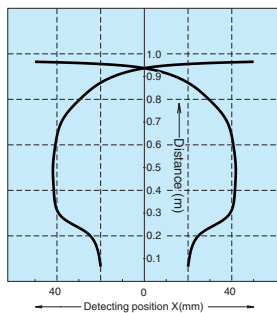
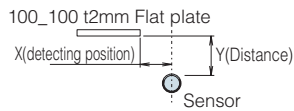

Round bar detection

Model USA-WR

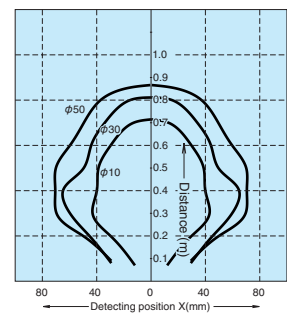
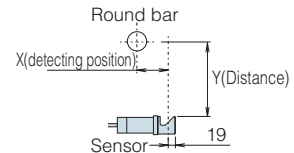
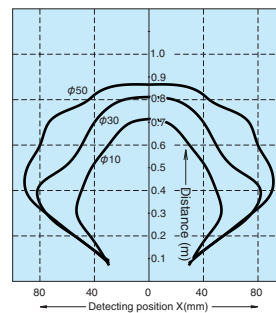
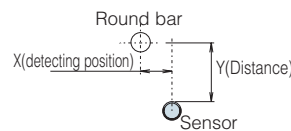

## Dimensions (in mm)

