



- Unique circuit achieving high accuracy (1 mm = 10 mV)
- Improved resistance to noise by the use of an ultrasonic frequency of 200 kHz
 - Resistance to dust and dirt, wide range of detectable objects including transparent objects, liquid, particles, etc.
 - Comparator output available

Type

Type	Detection distance	Model	Operation mode	Output mode
Reflective type	 0.08-1mm	US-1AH	Wave-ON/ Wave-OFF selectable (with switch)	• Analog output
		US-1AHPN		• Comparator output

Panel layout

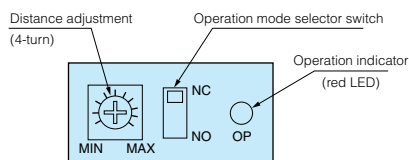

- The distance adjustment is a 4-turn volume. Turning clockwise increases the detecting distance up to about 1 m.
- Set the operation mode selector switch according to the application.

NC: Wave-OFF (normally "closed")

NO: Wave-ON (normally "open")

For using the analog output only, the operation above is unnecessary. Use the sensor with the factory setting enabled.

Indicators

The reception indicator (green LED) and operation indicator (red LED) on the panel respectively show different received signal levels as described in the figure.

The range of illumination for the operation indicator depends on the distance adjustment setting. The reception indicator is illuminated within the range of distance in which ultrasonic waves are received, although the boundaries may vary depending on the detection object. This indicates a margin of detection.

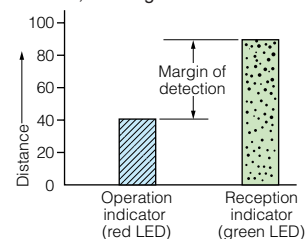

For detection of object with low ultrasonic reflectance such as rubber, the maximum detecting distance may be reduced.

Sample Applications

- Winding thickness control/measurement
- Detection of transparent objects/bottles
- Analog control of level of liquid/fine particles

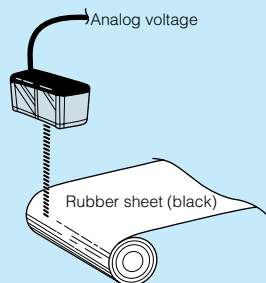

Ultrasonic wave sensor capable of detecting intense black rubber. Analog voltage output available for analog control.

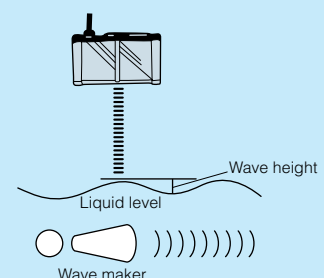
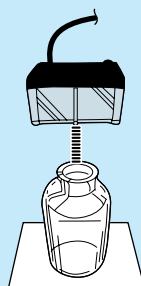

Wave height controlled in pool equipped with wave generator.

US-1AH

Rating/Performance/Specification

Type		Ultrasonic (analog output)	
Model		US-1AH	US-1AHPN
Detection method		Reflective type	
Detecting distance		80-1000 ±10mm With 40x 40mm aluminum plate	
Dead zone		60mm MAX	
Power supply		12-24V DC ±10% / Ripple 10% max.	
Current consumption		50mA max.	
Output mode	Analog output	0.6 -10VE Output impedance: 600 Ω	
	Comparator output	NPN open collector sink current 100 mA (30 VDC) max.	PNP open collector Source current 100 mA (30 VDC) max.
Operation mode		Wave-ON/Wave-OFF selectable (with switch)	
Minimum resolution		1mm=10mV	
Linearity		±3% FS (full scale)	
Response time		Analog output: 10V→2V 60ms 2V→10V 50ms analog response time + 10 ms	
Hysteresis		3% max. of detecting distance	
Ultrasonic frequency		186kHz±10kHz	
Indicator		Operation indicator: red LED (each on front/back) Reception indicator: green LED (front)	
Volume (VR)		Distance adjustment (4-turn without stopper) provided	
Switch (SW)		Wave-ON/Wave-OFF selector switch	
Protective feature		Output short circuit protection, protection against reverse connection	
Material		Case: aluminum / Lid: polycarbonate Front panel: acrylic resin / Back panel: ABS resin	
Connection		Permanently attached cord (φ 6.5) 0.3 mm² 4 cores, 2 m	
Mass		350 g max.	

Input/Output Circuit and Connection

US-1AH (NPN output)

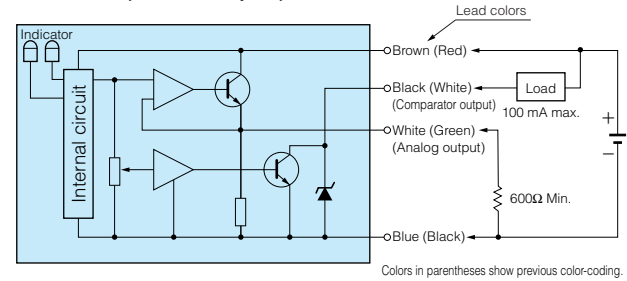

US-1AHPN (PNP output)

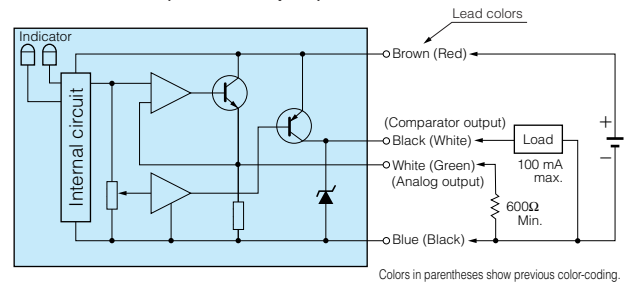

Dimensions (in mm)

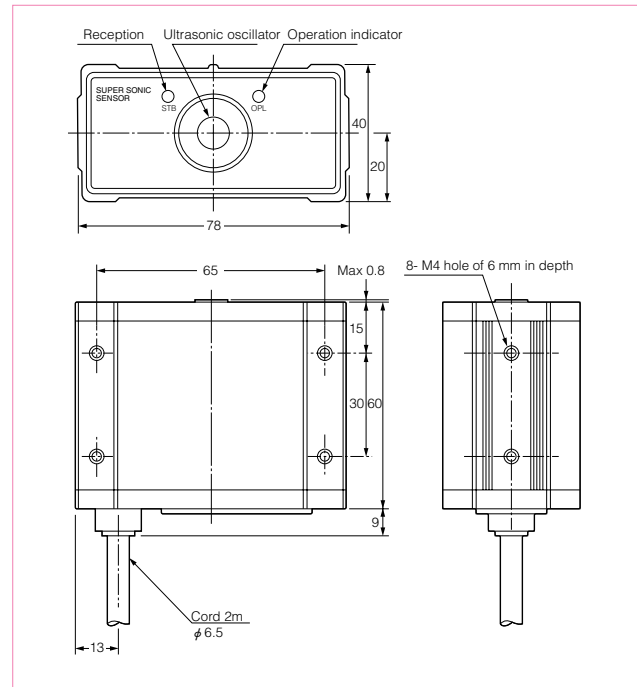

Environmental Specification

Environment		Specification
Ambient temperature		-10 - +55 °C (non-freezing)
Ambient humidity		35-85%RH (non-condensing)
Ambient wind speed		1m/s max
Protective structure		IP51
Vibration		10-55 Hz / 1.5 mm amplitude / 2 hours each in 3 directions
Shock		500 m/s² / 2 times each in 3 directions (ultrasonic element excluded)
Dielectric withstanding		500VAC for 1 minute
Insulation resistance		500 VDC, 20 MΩ or higher

Characteristics (Typical Example)

Activation area characteristics

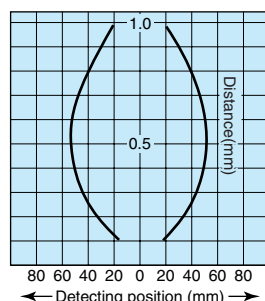

Distance-output characteristics

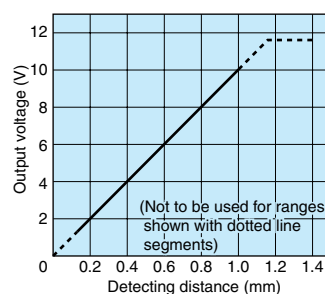

Applicable comparator



(ANP Series)